

EZ3 Enhanced Series 6" TFT Color Panels

(Great Replacement for PanelView 550, 600 with DH+)

EZ3 Enhanced Series Touchpanel feature:

- 400 NITs, 75K Hrs @ 55°C
- 320 x 240 screen resolution
- 5.7" diagonal color TFT
- Patented HMI on-line edit, No downtime
- Tiny EZminiWifi installed on the HMI allows Laptop to program HMI from 400 ft. away. \$49
- Only HMI that can still talk to AB's DH+
- EZTouch EZ3 Enhanced HMI have real time access to process data stored inside the HMI or the USB drive and the micro SD using AVG File Manager utility.
- EZTouch EZ3 Enhanced HMI in a plant or multiple plants have the capacity to be monitored using EZPlantview software.
- Best looking objects and animation with 65K colors.
- Most Rugged 0.090" thick anti-glare touch screen.
- Unicode for multiple languages.
- Easiest Programming Software, design time in hrs not days.
- Full Project simulation on your PC.
- "C level" scripting and logic expressions.
- Data-logging, Recipes, Emails, USBs. Free Chart recorder.
- Most advanced Alarm management and logging.
- On-Screen Recipe Edit.
- Every model Fully Loaded, No "R" Reduced Features models.
- Remote Monitoring and Control, Smart phones & Ethernet.
- Communicate to all PLCs, including DH+ & Ethernet IP.
- Dual PLC Drivers with automatic tag conversion.
- Mfr. cost reduction & IP protection for qualified customers.
- Unique Visibility tag for best screen space utilization.
- Pass-through programming for all PLCs.

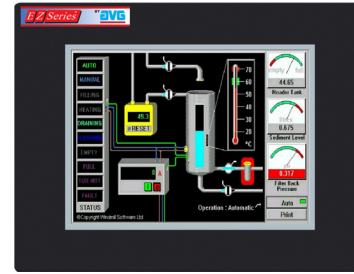

Model Number	Interface	Price	Del.
EZ3-T6C-EE	All serial and Ethernet drivers	See Web	STK
EZ3-T6C-EEH	Serial, Ethernet and Allen-Bradley's DH+	See Web	STK

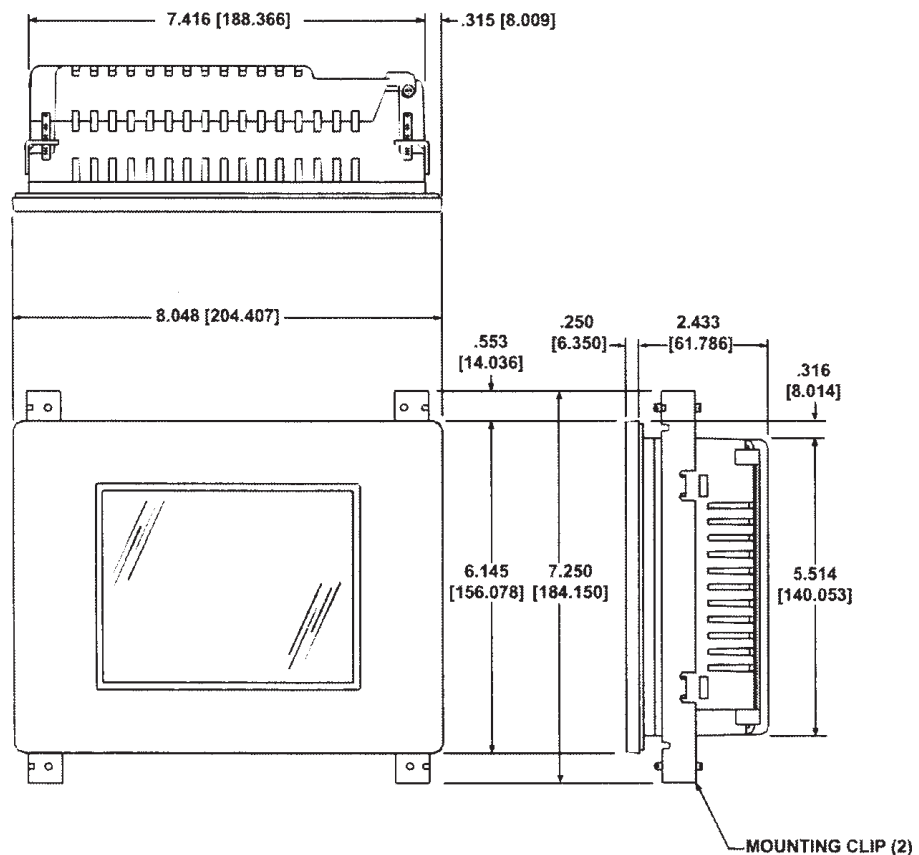

Proudly Made in America

EZ3 Enhanced Series 7" (Wide) TFT Color Panels

EZ3 Enhanced Series Touchpanel feature:

- 400 NITs, 75K Hrs @ 55°C
- 800 x 480 screen resolution
- 7" diagonal color TFT
- Patented HMI on-line edit, No downtime
- Tiny EZminiWifi installed on the HMI allows Laptop to program HMI from 400 ft. away. \$49
- EZTouch EZ3 Enhanced HMI have real time access to process data stored inside the HMI or the USB drive and the micro SD using AVG File Manager utility.
- EZTouch EZ3 Enhanced HMI in a plant or multiple plants have the capacity to be monitored using EZPlantview software.
- Best looking objects and animation with 65K colors.
- Most Rugged 0.090" thick anti-glare touch screen.
- Unicode for multiple languages.
- Easiest Programming Software, design time in hrs not days.
- Full Project simulation on your PC.
- "C level" scripting and logic expressions.
- Data-logging, Recipes, Emails, USBs. Free Chart recorder.
- Most advanced Alarm management and logging.
- On-Screen Recipe Edit.
- Every model Fully Loaded, No "R" Reduced Features models.
- Remote Monitoring and Control, Smart phones & Ethernet.
- Communicate to all PLCs.
- Dual PLC Drivers with automatic tag conversion.
- Mfr. cost reduction & IP protection for qualified customers.
- Unique Visibility tag for best screen space utilization.
- Pass-through programming for all PLCs.

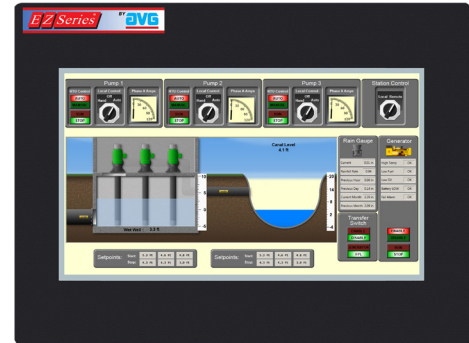

Model Number	Interface	Price	Del.
EZ3-T7C-EE	All serial and Ethernet drivers	See Web	STK

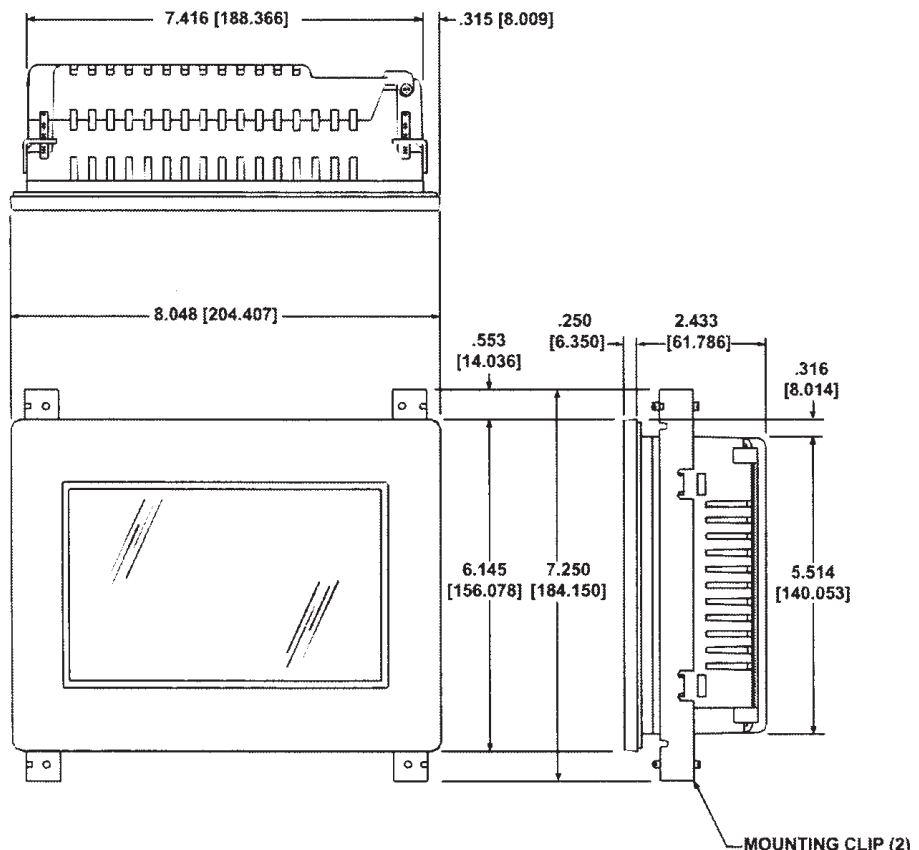

Proudly Made in America

EZ3 Enhanced Series 8" TFT Color Panels

(Great Replacement for PanelView 700, 900 with DH+)

EZ3 Enhanced Series Touchpanel feature:

- 400 NITs, 75K Hrs @ 55°C
- 800 x 600 screen resolution
- 8.4" diagonal color TFT
- Patented HMI on-line edit, No downtime
- Tiny EZminiWifi installed on the HMI allows Laptop to program HMI from 400 ft. away. \$49
- Only HMI that can still talk to AB's DH+
- EZTouch EZ3 Enhanced HMI have real time access to process data stored inside the HMI or the USB drive and the micro SD using AVG File Manager utility.
- EZTouch EZ3 Enhanced HMI in a plant or multiple plants have the capacity to be monitored using EZPlantview software.
- Best looking objects and animation with 65K colors.
- Most Rugged 0.090" thick anti-glare touch screen.
- Unicode for multiple languages.
- Easiest Programming Software, design time in hrs not days.
- Full Project simulation on your PC.
- "C level" scripting and logic expressions.
- Data-logging, Recipes, Emails, USBs. Free Chart recorder.
- Most advanced Alarm management and logging.
- On-Screen Recipe Edit.
- Every model Fully Loaded, No "R" Reduced Features models.
- Remote Monitoring and Control, Smart phones & Ethernet.
- Communicate to all PLCs, including DH+ & Ethernet IP.
- Dual PLC Drivers with automatic tag conversion.
- Mfr. cost reduction & IP protection for qualified customers.
- Unique Visibility tag for best screen space utilization.
- Pass-through programming for all PLCs.

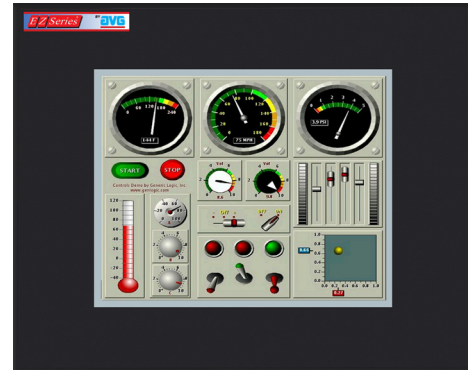

Model Number	Interface	Price	Del.
EZ3-T8C-EE	All serial and Ethernet drivers	See Web	STK
EZ3-T8C-EEH	Serial, Ethernet and Allen-Bradley's DH+	See Web	STK

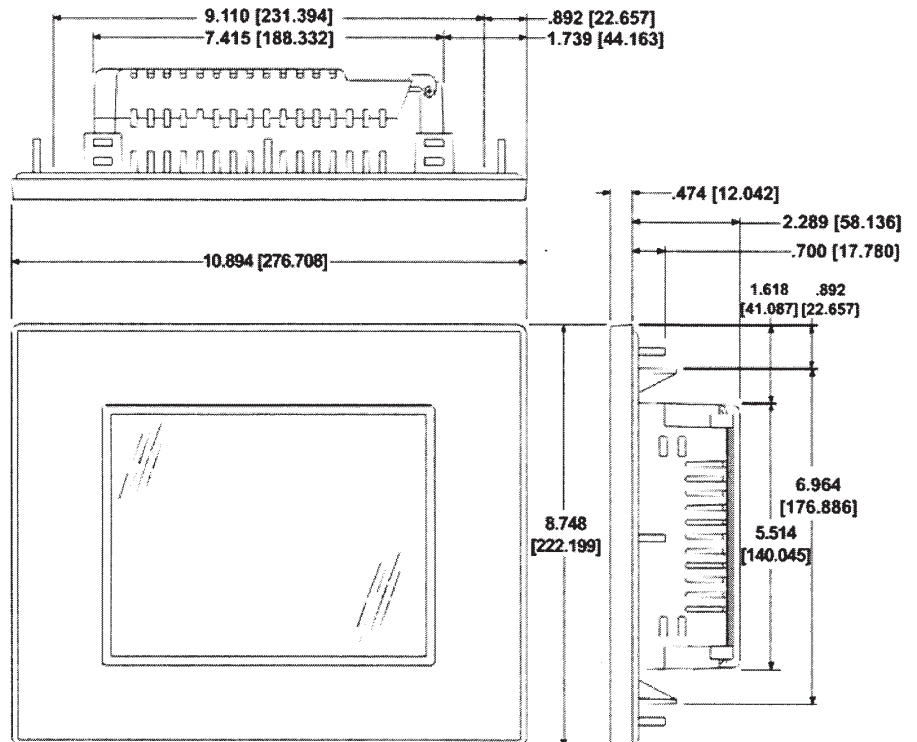

Proudly Made in America

EZ3 Enhanced Series 10" TFT Color Panels (Great Replacement for PanelView 1000, 1000E with DH+)

EZ3 Enhanced Series Touchpanel feature:

- 400 NITs, 75K Hrs @ 55°C
- 800 x 600 screen resolution
- 10.4" diagonal color TFT
- Patented HMI on-line edit, No downtime
- Tiny EZminiWifi installed on the HMI allows Laptop to program HMI from 400 ft. away. \$49
- Only HMI that can still talk to AB's DH+
- EZTouch EZ3 Enhanced HMI have real time access to process data stored inside the HMI or the USB drive and the micro SD using AVG File Manager utility.
- EZTouch EZ3 Enhanced HMI in a plant or multiple plants have the capacity to be monitored using EZPlantview software.
- Best looking objects and animation with 65K colors.
- Most Rugged 0.090" thick anti-glare touch screen.
- Unicode for multiple languages.
- Easiest Programming Software, design time in hrs not days.
- Full Project simulation on your PC.
- "C level" scripting and logic expressions.
- Data-logging, Recipes, Emails, USBs. Free Chart recorder.
- Most advanced Alarm management and logging.
- On-Screen Recipe Edit.
- Every model Fully Loaded, No "R" Reduced Features models.
- Remote Monitoring and Control, Smart phones & Ethernet.
- Communicate to all PLCs, including DH+ & Ethernet IP.
- Dual PLC Drivers with automatic tag conversion.
- Mfr. cost reduction & IP protection for qualified customers.
- Unique Visibility tag for best screen space utilization.
- Pass-through programming for all PLCs.

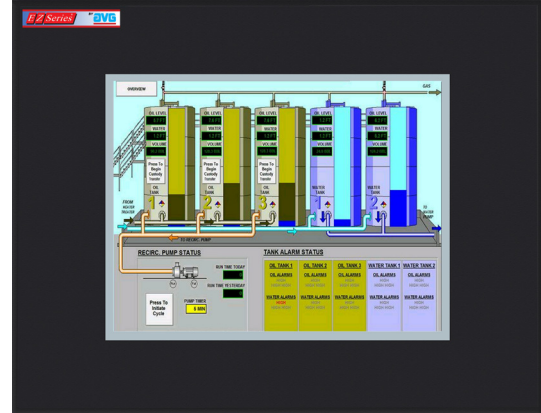

Model Number	Interface	Price	Del.
EZ3-T10C-EE	All serial and Ethernet drivers	See Web	STK
EZ3-T10C-EEH	Serial, Ethernet and Allen-Bradley's DH+	See Web	STK

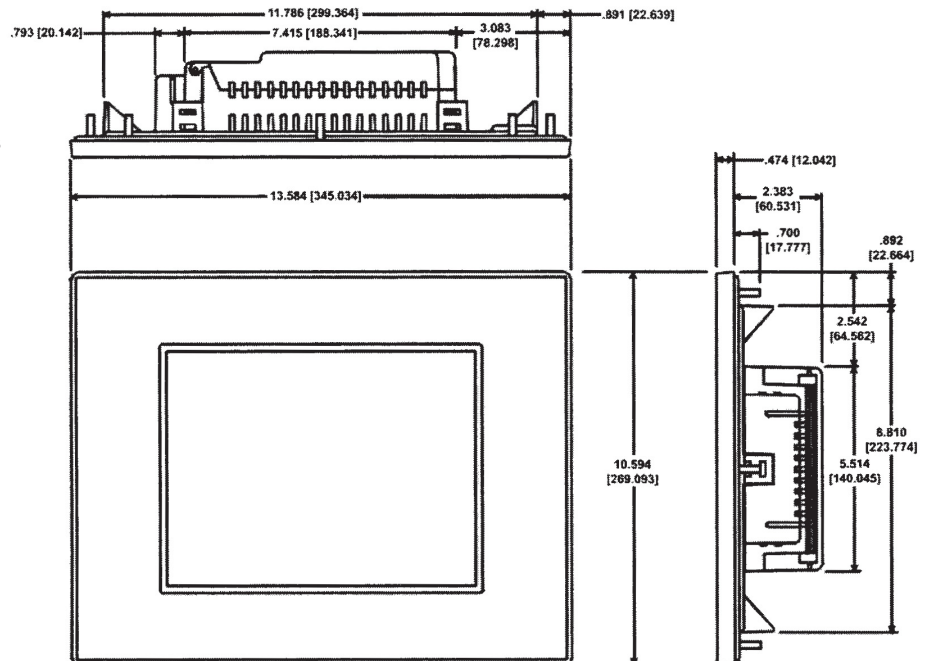

Proudly Made in America

EZ3 Enhanced Series 12" TFT Color Panels (Great Replacement for PanelView 1000, 1000E with DH+)

EZ3 Enhanced Series Touchpanel feature:

- 400 NITs, 75K Hrs @ 55°C
- 800 x 600 screen resolution
- 12" diagonal color TFT
- Patented HMI on-line edit, No downtime
- Tiny EZminiWifi installed on the HMI allows Laptop to program HMI from 400 ft. away. \$49
- Only HMI that can still talk to AB's DH+
- EZTouch EZ3 Enhanced HMI have real time access to process data stored inside the HMI or the USB drive and the micro SD using AVG File Manager utility.
- EZTouch EZ3 Enhanced HMI in a plant or multiple plants have the capacity to be monitored using EZPlantview software.
- Best looking objects and animation with 65K colors.
- Most Rugged 0.090" thick anti-glare touch screen.
- Unicode for multiple languages.
- Easiest Programming Software, design time in hrs not days.
- Full Project simulation on your PC.
- "C level" scripting and logic expressions.
- Data-logging, Recipes, Emails, USBs. Free Chart recorder.
- Most advanced Alarm management and logging.
- On-Screen Recipe Edit.
- Every model Fully Loaded, No "R" Reduced Features models.
- Remote Monitoring and Control, Smart phones & Ethernet.
- Communicate to all PLCs, including DH+ & Ethernet IP.
- Dual PLC Drivers with automatic tag conversion.
- Mfr. cost reduction & IP protection for qualified customers.
- Unique Visibility tag for best screen space utilization.
- Pass-through programming for all PLCs.

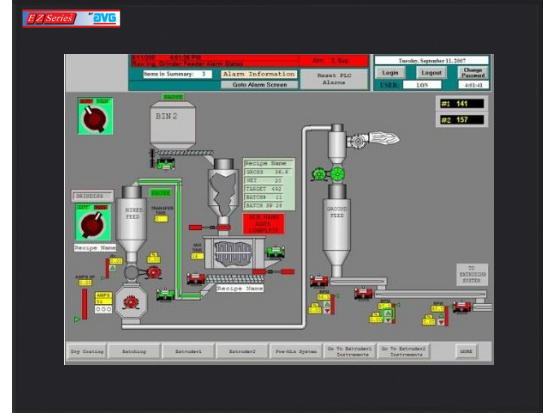

Model Number	Interface	Price	Del.
EZ3-T12C-EE	All serial and Ethernet drivers	See Web	STK

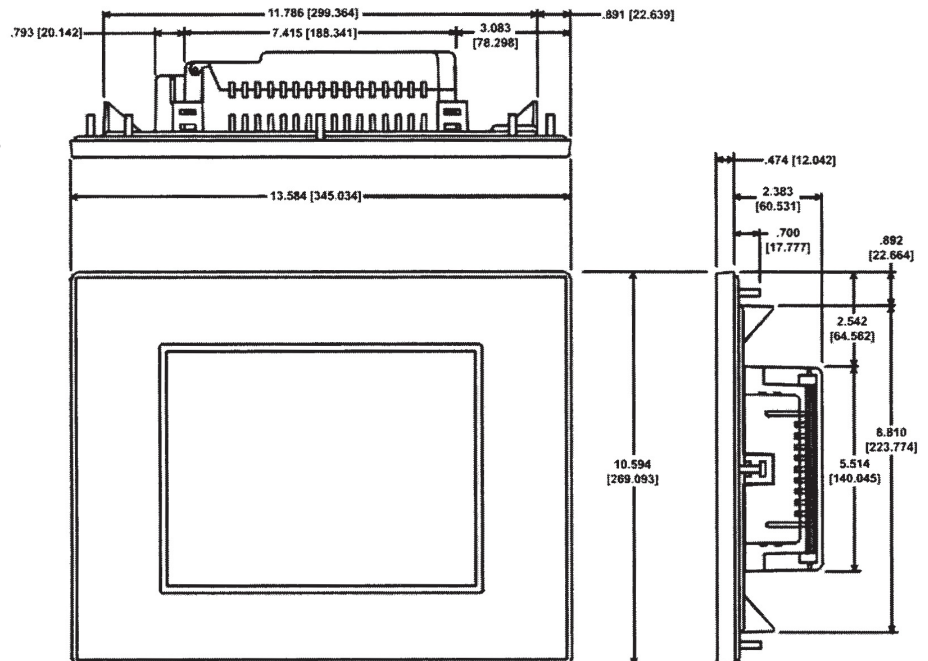

Proudly Made in America

EZ3 Enhanced Series 15" TFT Color Panels

(Great Replacement for PanelView 1200, 1400, 1400E with DH+)

EZ3 Enhanced Series Touchpanel feature:

- 400 NITs, 75K Hrs @ 55°C
- 1024 x 768 screen resolution
- 15" diagonal color TFT
- Patented HMI on-line edit, No downtime
- Tiny EZminiWifi installed on the HMI allows Laptop to program HMI from 400 ft. away. \$49
- Only HMI that can still talk to AB's DH+
- EZTouch EZ3 Enhanced HMI have real time access to process data stored inside the HMI or the USB drive and the micro SD using AVG File Manager utility.
- EZTouch EZ3 Enhanced HMI in a plant or multiple plants have the capacity to be monitored using EZPlantview software.
- 1024x768 resolution
- 1 GB Ethernet Port for Programming, Webserver access and PLC Communications
- 4 USB 2.0 Ports, including 1 for programming
- MicroSD Card capable
- Intel Atom E640 1 GHz processor
- 1GB DDR RAM
- Best looking objects and animation with 65K colors.
- Most Rugged 0.090" thick anti-glare touch screen.
- Unicode for multiple languages.
- Easiest Programming Software, design time in hrs not days.
- Full Project simulation on your PC.
- "C level" scripting and logic expressions.
- Data-logging, Recipes, Emails, USBs. Free Chart recorder.
- Most advanced Alarm management and logging.
- On-Screen Recipe Edit.
- Every model Fully Loaded, No "R" Reduced Features models.
- Remote Monitoring and Control, Smart phones & Ethernet.
- Communicate to all PLCs, including DH+ & Ethernet IP.
- Dual PLC Drivers with automatic tag conversion.
- Mfr. cost reduction & IP protection for qualified customers.
- Unique Visibility tag for best screen space utilization.
- Pass-through programming for all PLCs.

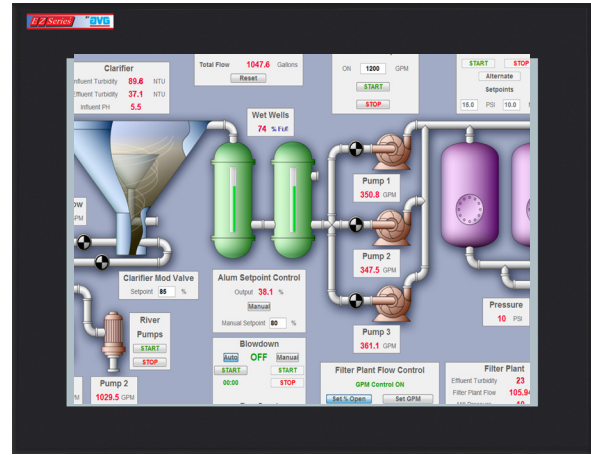

Model Number	Interface	Price	Del.
EZ3-T15C-EE	All serial and Ethernet drivers	See Web	STK
EZ3-T15C-EEH	Serial, Ethernet and Allen-Bradley's DH+	See Web	STK

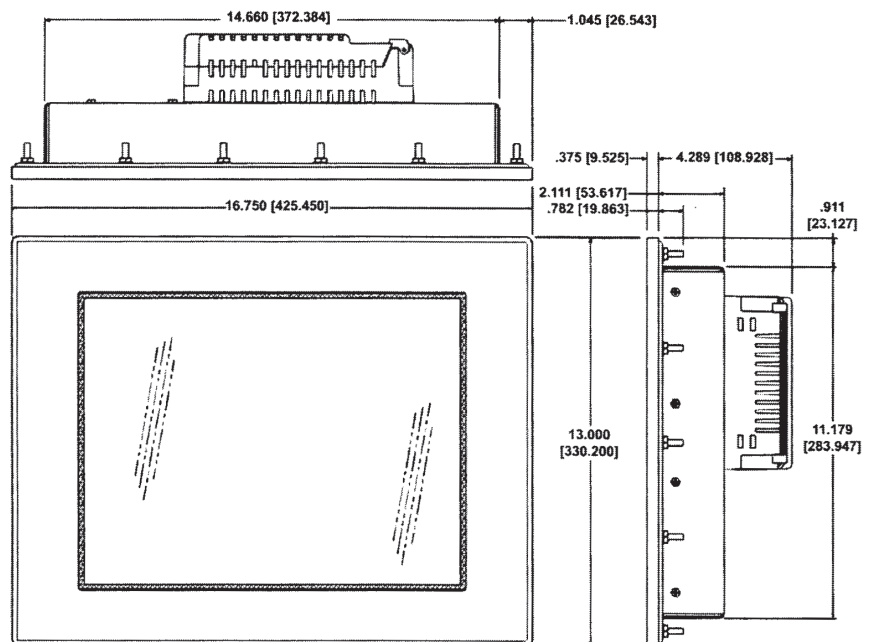

Proudly Made in America