



# Hardware manual



DESIGNED, MANUFACTURED and DISTRIBUTED by

4140 Utica Ridge Rd. • Bettendorf, IA 52722-1327

Phone: 1-877-774-3279 • Fax: 1-877-775-3279 • [www.EZAutomation.net](http://www.EZAutomation.net)



Division of 

AVG/EZAutomation

## Table of contents

---

Warnings .....	3
Product Overview .....	4
Specifications .....	5
Installation Considerations .....	7
Safety Considerations .....	7
Installation Considerations .....	8
Electrical Considerations .....	9
Shielding from RFI.....	10
Installation .....	12
Mounting Information.....	12
Powering the Unit.....	15
Communication and Ports .....	16
PLC Port .....	16
COM1 Port .....	17
Ethernet Port .....	18
Micro SD slot.....	20
USB Ports .....	20
Programming the Panel.....	21
Create a Project .....	21
Transfer a Project.....	24
Data Logging Overview.....	25
Maintenance and Troubleshooting .....	31
Hardware Maintenance .....	31
Changing the Battery.....	32
Update Firmware.....	33
Troubleshooting .....	35

## Warnings

---

Programmable control devices such as the EZ3 Series are not fail-safe devices and as such must not be used for stand-alone protection in any application. Unless proper safeguards are used, unwanted start-ups could result in equipment damage or personal injury. The operator must be made aware of this hazard and appropriate precautions must be taken.

In addition, consideration must be given to the use of an emergency stop function that is independent of the EZ3 Series.

The diagrams and examples in this user manual are included for illustrative purposes only. The manufacturer cannot assume responsibility or liability for actual use based on the diagrams and examples.

### Trademarks

This publication may contain references to products produced and/or offered by other companies. The product and company names may be trademarked and are the sole property of their respective owners. AVG Automation disclaims any proprietary interest in the marks and names of others.

**Manual part number: EZ3-Touch-M**  
**© Copyright 2017, Version 2.0, EZ Automation**  
**All Rights Reserved**

No part of this document shall be copied, reproduced, or transmitted in any way without the prior written consent of AVG Automation. AVG Automation retains the exclusive rights to all information included in this document.

### Designed, Built and Distributed by AVG

4140 Utica Ridge Rd. · Bettendorf, IA 52722-1327

Phone: **1-877-774-EASY** · Fax: **1-877-775-EASY** · [www.ezautomation.net](http://www.ezautomation.net)

### EU Information

The EZ3 Series is manufactured in compliance with European Union (EU) Directives and carries the CE mark. They been tested under CE Test Standard #EN55011, and is submitted for UL Certification.

Products with CE marks perform their required functions safely and adhere to relevant standards as specified by EU directives provided they are used according to their intended purpose and that the instructions in this manual are adhered to. The protection provided by the equipment may be impaired if this equipment is not used in accordance with this manual. Only replacement parts supplied by AVG Automation or its agents should be used.

### Technical Support

Consult PLC Editor Programming Software Help. You may also find answers to your questions in the operator interface section of our website @ [www.ezautomation.net](http://www.ezautomation.net). If you still need assistance, please call our technical support at 1-877-774-EASY or FAX us at 1-877-775-EASY.

### SELV Circuits

All electrical circuits connected to the communications port receptacle are rated as Safety Extra Low Voltage (SELV).

### Preventative and Maintenance Cleaning

No special preventative measurement is required.

## Product Overview

---

Thank You for using EZ Automation's new line of stunning HMIs - the EZ3 Enhanced Series. As the latest in a long line of high performing and easy programming HMIs, the EZ3 Enhanced Series is both convenient and fast to use. In addition, the EZ3 Enhanced Series provides several enhancements over its predecessors including additional communication ports, higher resolution, a standard MicroSD slot, and built in remote monitoring and control features.



This manual presents information on the installation, communication and specifications of the EZ3 Enhanced Series. It also covers the troubleshooting and maintenance of an existing setup and provides understanding on how to program the panel with our EZTouch Editor Software.





## Notices

Please note the battery tab/slip in all new units. The battery tab needs to be removed before operation of a new unit. It is intentionally placed, so that the battery does not drain as a unit sits idle before operation.

When beginning to use a fresh EZ3 Enhanced Series HMI understand that the unit requires an initial double power cycle. First, remove the battery tab and power on the unit to charge it. It will then require a reboot to begin operating. After that it will always work as normal upon initial power up.

# EZ3 Enhanced Series Selection Guide & Specifications

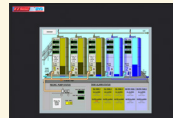
## EZ3 Enhanced Series 6", 7", 8" and 10" Model Specifications

Part Number	EZ3-T6C-EE - \$599	EZ3-T7C-EE - \$549	EZ3-T8C-EE - \$1049	EZ3-T10C-EE - \$1349	EZ3-T12C-EE - \$1499
					
<b>Specification</b>	6" TFT Color Slim Bezel	7" Wide TFT Color Slim Bezel	8" TFT Color Slim Bezel	10" TFT Color Slim Bezel	12" TFT Color Slim Bezel
<b>Enclosure</b>	NEMA 4, 4X (indoor)				
<b>Display Type</b>	5.7" TFT (65K Colors)	7" TFT (65K Colors)	8" TFT (65K Colors)	10.4" TFT (65K Colors)	12" TFT (65K Colors)
<b>Display View Area</b>	4.65"x3.5" (118.1 x 88.9mm)	6.49"x3.9" (164.9 x 100mm)	6.05"x4.55" (153.7 x 115.8mm)	8.31"x6.22" (211.07 x 158mm)	9.68" x 7.26" (246 x 184.5 mm)
<b>Screen Pixels</b>	320x240	800 x 480	640 x 480	800 x 600	800 x 600
<b>Brightness/Life</b>	400 nits/75,000 hours (Even at extreme Operating Temp.)				300 nits/50K hrs@50°C
<b>Backlight</b>	White LED Strips				
<b>Touch Screen</b>	Analog Resistive Touch Screen				
<b>Service Power</b>	24 VDC (20-30 VDC Operating Range), 1.5A switching supply recommended				
<b>Operating Temperature</b>	0-55°C (32 - 131°F)				0-50°C (32 - 122°F)
<b>Backlight Power</b>	OFF	8 Watts @ 24 VDC			
	ON	15 Watts @ 24 VDC	15 Watts @ 24 VDC	15 Watts @ 24 VDC	18 Watts @ 24 VDC
<b>Storage Temp.</b>	-25 to 65°C (-13 to 149°F)				
<b>Humidity</b>	10-95% RH, non-condensing				
<b>Electrical Noise</b>	NEMA ICS 2-230 showering arc ANSI C37.90a-1974 SWC Level C Chattering Relay Test				
<b>Withstand Voltage</b>	1000 VDC (1 Minute), between power supply input terminal and protective ground (FG)				
<b>Insulation Res.</b>	Over 20 MΩ , between power supply input terminal and protective ground (FG)				
<b>Vibration</b>	5 to 55Hz 2G for 2 hours in the X, Y and Z axes				
<b>Shock</b>	10G for under 12ms in the X, Y and Z axes				
<b># of Screens</b>	Up to 999 limited by memory				
<b>Real Time Clock</b>	Built into Panel (PLC clock is still accessible if available)				
<b>Screen Saver</b>	Yes, Backlight off				
<b>Serial/Ethernet Communications</b>	PLC port: RS-232/RS-422/RS-485 15-Pin D-Sub (female)				
<b>Serial/Ethernet Communications Option Cards</b>	Download/program port: RS-232/RS-422/RS-485 9-pin D-sub (female)				
	Ethernet Built-in (10/100 Base-T)				
<b>USB &amp; MicroSD ports</b>	DataHighway plus (-EEH models)				
<b>External Dimensions</b>	1 USB port for programming, 1 USB port for Datalogging and 1 microSD slot for additional data storage				
<b>Weight</b>	6.145"x8.048"x2.433" (156.078x204.407 x51.786mm)	6.145"x8.048"x2.433" (156.078x204.407 x51.786mm)	8.748"x10.894"x2.289" (222.199x276.708 x58.136mm)	10.59"x13.58"x2.86" (268.99x344.93 x72.64mm)	10.59"x13.58"x2.86" (268.99x344.93x72.64mm)
<b>Agency Approval</b>	1.7 lbs	1.7 lbs	2.9 lbs	3.8 lbs	3.8 lbs
	UI, cUL, CE				

# EZ3 Enhanced Series 15" Specifications

## EZ3 Enhanced Series 15" Model Specifications

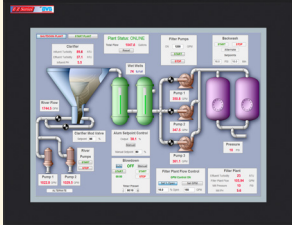
<b>Part Number</b>			EZ3-T15C-ES (Full Featured w/Ethernet) <b>\$1999</b>
			EZ3-T15C-EH (Serial, Ethernet and Allen-Bradley's DH+) <b>\$3699</b>
<b>Specification</b>	15" color slim bezel	<b>Humidity</b>	10-95% RH, noncondensing
<b>Enclosure</b>	NEMA 4, 4X (indoor)	<b>Electrical Noise</b>	NEMA ICS 2-230 showering arc ANSI C37.90a-1974 SWC Level C Chattering Relay Test
<b>Display Type</b>	15.0" TFT w/Built-in Anti-glare	<b>Withstand Voltage</b>	1000VDC (1 minute), between power supply input terminal and protective ground (FG)
<b>Display View Area</b>	12.02"x9.01" (305.28 x 228.96mm)	<b>Insulation Res.</b>	Over 20 MΩ, between power supply input and terminal and protective ground (FG)
<b>Screen Pixels</b>	1024x768	<b>Vibration</b>	5 to 55Hz 2G for 2 hours in the X, Y and Z axes
<b>Colors</b>	16.2M	<b>Shock</b>	10G for under 12ms in the X, Y and Z axes
<b>Brightness/Life</b>	400 nits/75,000 hours	<b>User Memory</b>	16GB SSD, 1GB DDR2 RAM
<b>Touch Screen</b>	Analog Resistive Touch	<b># of Screens</b>	Up to 999 limited by memory
<b>CPU Type</b>	Intel Atom E640 1 GHz processor	<b>Real Time Clock</b>	Built into panel (PLC clock is still accessible if available)
<b>Service Power</b>	24VDC (20-30VDC operating range), 1.5A switching supply recommended	<b>Screen Saver</b>	Yes, Backlight off
<b>Power</b>	Back-light On	18 Watts @ 24VDC	<b>Serial and Ethernet Communications</b>
	Back-light Off	9 Watts @ 24VDC	
<b>Agency Approval</b>	UL, CUL, CE		
<b>Operating Temp.</b>	0 to 55°C (32 to 131°F)		Download/program port: RS-232/RS-422/RS-485 9-pin D-sub (female)
<b>Storage Temp.</b>	-25 to 65°C (-13 to 149°F)		Ethernet with 10/100 BaseT
<b>External Dimensions</b>	13"x16.75"x4.66" (332x425.25x118.36mm)		<b>USB</b>
			4 USB 2.0 Ports (Programming, Datalogging and Peripheral devices)
		<b>Micro SD Card Slot</b>	Data Logging
		<b>Weight</b>	7 lbs

Proudly Made in America

## Safety Considerations

Please follow all applicable local and national codes to ensure maximum safety of the equipment and personnel. The installation and operational environment must be maintained per the latest revision of these codes.

You are responsible to determine the codes to be followed and to verify the compliance of equipment, installation, and operation with the latest revision of these codes.

It is an absolute must to follow all applicable sections of:

- The National Fire Code
- The National Electrical Code (NEC)
- The National Electrical Manufacturer's Association (NEMA) codes

## Safety Guidelines

Safety is the most important element of a proper system installation. Adhering to these safety considerations ensures the safety of yourself and others, as well as the condition of your equipment. We recommend reviewing the following safety guidelines:

### *1) Disconnecting Main Power*

The main power switch should be easily accessible to the operators and maintenance personnel. It is important to make sure that all other sources of power including pneumatic and hydraulic are de-energized before starting the work on a machine or process controlled by the HMI.

### *2) Safety Circuits*

Most of the machines are installed with safety circuits such as limit switches, emergency stop push buttons, and interlocks. These circuits should always be hardwired directly to the EZ3 unit. These devices must be wired in series so that when any one device opens, the unit is automatically de-energized. This removes power to the machine. These circuits should not be altered in any case, since this could result in serious injury or damage to the machine.

### *3) Fail-Safe Operation*

Our products are not fault-tolerant. They are not designed or intended for use as online control equipment in hazardous environments requiring fail-safe performance, such as in operation of nuclear facilities, aircraft navigation or communication systems, air traffic control, direct life-support machines, weapons systems, clutch control systems on presses, in which the failure of the product could lead directly to death, personal injury or severe physical or environmental damage. External fail-safe and/or redundant components are required to make your control system fail-safe.

## Installation Considerations

Our products have been designed and tested for operation in the most demanding industrial environments. Modern solid-state industrial controls are complex electronic equipment that operate at low levels of voltage and current, co-existing with components that operate at much higher levels of power. The difference in operating power characteristics between the high and low power control devices creates the possibility of unwanted signals being generated, thus causing interference. The interference, which is a by-product of electrical noise, is not present at all times. However, if it appears at random and for brief periods of time, it can cause disruptions and errors in the operation of a control system.

Enhancement of a system's noise level immunity and its tolerance to other environmental hazards can be accomplished by following proper system installation guidelines. The recommendations are of a general nature and constitute good industrial installation practice.

## General Environmental Considerations

Avoid installing the EZ3 unit in areas where the following conditions may exist:

- Environmental temperatures above or below those specified for the EZ3 unit
- Prolonged exposure to humidity and liquids which may be sprayed or splashed on the equipment
- Dusty environments where airborne particles may accumulate on equipment causing reduction of heat dissipation and reduction in effective electrical spacing between components
- Areas with excessive vibration
- Areas with high-radiated electrical noise, such as near fields of transmitting antennas and areas in close proximity of arc welding stations

## Physical Layout in a Control Cabinet

When possible, cabinets housing electronic equipment should be designed with provisions for natural or forced ventilation to facilitate heat dissipation. Observe the following rules for cabinet installation:

- Heat generating equipment (power supplies and other heat inducing components) should be installed toward the top of the cabinet. The lower space in the cabinet is cooler than the top area.
- Install heat-sensitive components in the lower section.
- Provide enough space between components to allow a free flow of air for better heat dissipation.
- Provide the maximum possible physical separation between solid state and electromechanical controls. If possible, the electromechanical controls (motors, starters, solenoids, etc.) should be housed separately or at the farthest point when enclosed within the cabinet.

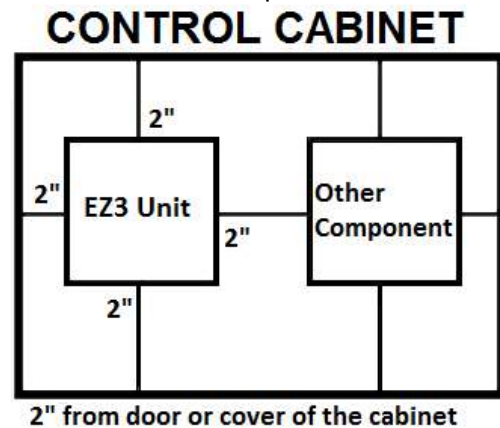



We recommend that the unit has a minimum clear space of 2" on all sides for adequate ventilation as shown in the image on the right.

## Electrical Considerations

This section is designed to provide you with a very basic understanding of electrical noise and how to keep it away from CPUs. Industrial plants have a number of generators of electrical noise that are sometimes also referred to as Radio Frequency Interference (RFI). Anytime an inductive load like a motor, motor starter, or solenoid is turned off, it generates a burst of excess energy that has to flow back to ground, just like electrical energy from a lightning storm has to flow back to Earth. RFI is short bursts of electrical energy at very high frequencies. Other sources include RF Welders or Radio Transmitters.

### Effect of RFI on Electronic Automation Equipment

Electronic controls use faster and faster CPUs today. These CPUs are also operating at 2.5V to 5VDC logic level power supply. RFI, if allowed to enter the CPU inside, is a killer of logic. A CPU under this environment loses its brain and behaves erratically. A smart industrial-grade CPU like the unit's card engine, when faced with RFI, halts its operation instead of giving false outputs.

### Types of RFI

RFI enters electronic controls in two ways: radiated RFI or conducted RFI. For most practical purposes, electronic devices, unless sitting right next to a powerful RFI transmitter, will not be affected by noise because air space severely attenuates such interference. On the other hand, conducted RFI travels over conductive surfaces such as power supply wires, electrical wiring of field devices, and worst of all; improper ground planes.

Equipment cabinets usually incorporate one or two doors and/or hinged cabinet panels. Relying on door hinges and swinging panels for a good metallic bond between hinged parts and the main body of the cabinet does not insure adequate grounding. Instead, the use of ground straps is recommended. It is vital for the reliable operation of any electronic device to have any of its metallic surfaces well-grounded to Earth. This not only provides for safe operation, it will also drain out any conducted RFI to Earth, away from the CPU's signal ground.

## Shielding from RFI

### Shielded Cables

Power cables, I/O cables or wiring, and communication cables should all be separate so that they do not couple the conducted RFI on any of these wires/cables. Another path for RFI into the PLC is through its RS232 port. Hence, the cables to this port must be shielded properly.

### Equipment Cabinets

As mentioned, equipment cabinets typically incorporate one or two doors and/or hinged cabinet panels. In addition, sub-panels may be utilized on those electronic controls and electromechanical items that are mounted. The goal is to create a medium for mounting the equipment and ensure grounding of the control's chassis to it. However, the door hinges and swinging panels by themselves are not enough to ensure adequate grounding.

Similarly, the equipment enclosures are generally either painted or anodized. Mounting of painted or anodized enclosures to like surfaces also does not ensure good metallic contact between the equipment chassis and cabinet. It is imperative that the equipment chassis are grounded such as through the use of grounding straps as illustrated below.

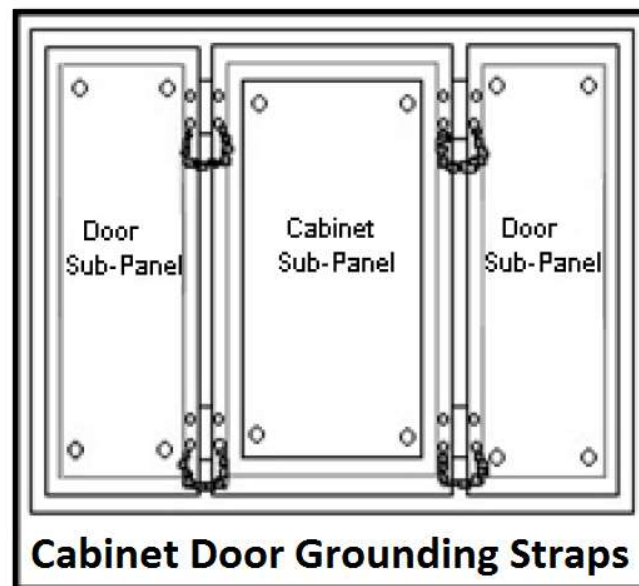

## Cabinet Wiring

The wiring of the EZ3 unit to the “field” outside the cabinet must be by design. The wiring cannot be random in order to get the various points of the cabinet and the “field” electrically connected. Below are some general rules that apply in most situations:

- Provide a separate power source to electronic controls and keep this power bus away from any I/O power.
- The cabinet should be wired with a safety ground (the main safety ground wire gauge is determined by the cabinet’s total current consumption) and in accordance with all electrical code requirements.
- Once the cabinet doors, stationary sub-panels and swing-out sub-panels have been “strapped” to the main cabinet, it is not necessary to run safety ground wires from the equipment chassis terminals to the main safety ground connection.
- The safety ground terminal of each component can, and should be, connected with the shortest wire possible, to the cabinet or sub-panel frame.
- Plan the wiring routing. Keep all switched power in separate ducts and if there is AC and DC power being switched, keep the wiring of each branch separate from all wires and cables carrying low level signals.
- Keep all three phase power outside of the cabinet, but if it becomes necessary, keep the runs as short as possible and maintain the maximum possible distance between the three phase bus and all other wiring.
- Primary power leads to the control equipment (Base power terminals) should be made with a two wire twisted cable with approximately 12 turns per foot. The length of these cables should be kept to a minimum, and to the greatest extent possible, such cable runs should be kept separate from other wiring.

## Mounting Information

### Cutout Dimensions

Units: inches [millimeters]

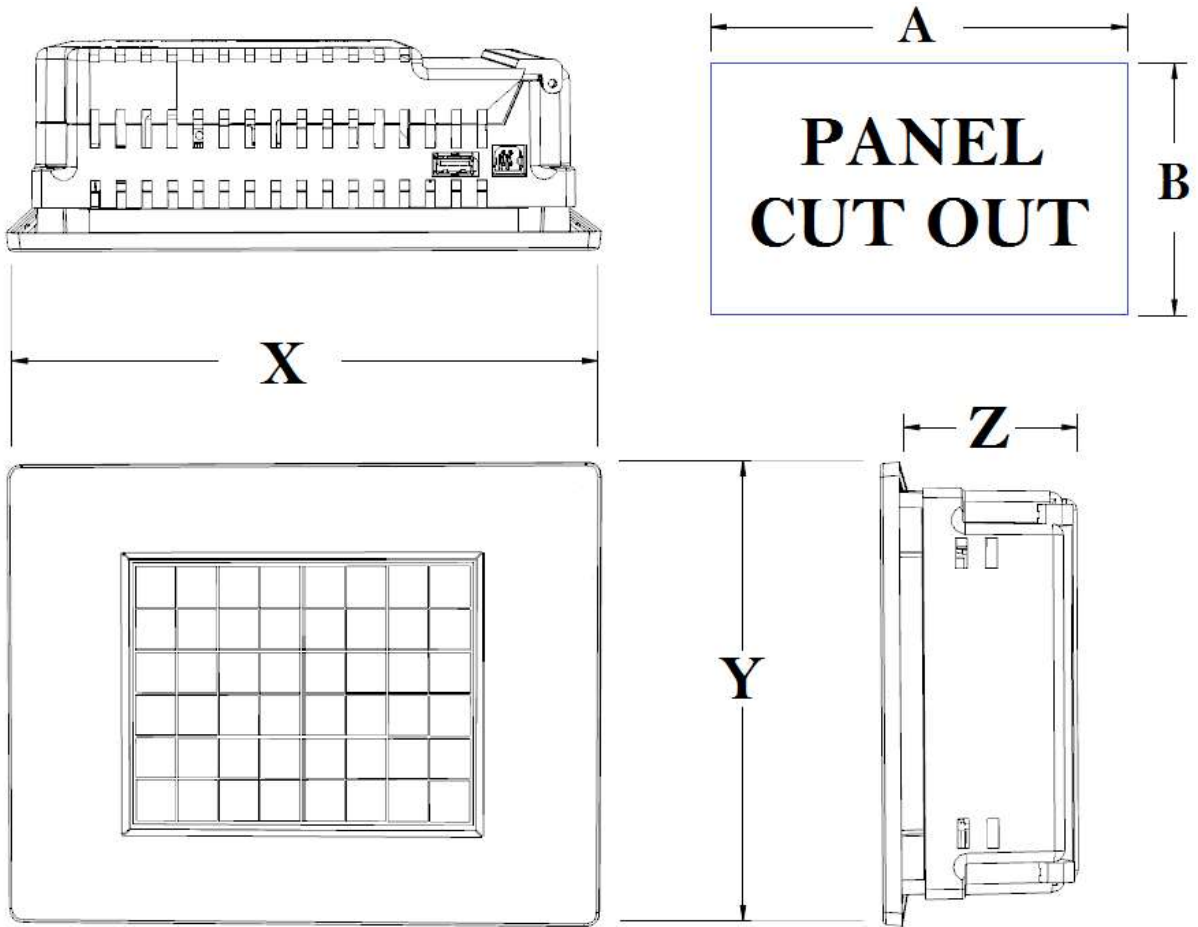

### EZ3 Panel Dimensions

Unit Size	X	Y	Z
6"	8.05" [204.42mm]	6.15" [156.11mm]	2.43" [61.72mm]
7"	8.05" [204.42mm]	6.15" [156.11mm]	2.43" [61.72mm]
8"	10.89" [276.71mm]	8.75" [222.20mm]	2.29" [58.14mm]
10"	13.58" [345.03mm]	10.59" [269.09mm]	2.86" [72.64mm]

### Panel Cutout Dimensions

Unit Size	A	B	Depth
6"	7.46" [189.48mm]	5.56" [141.22mm]	3.43" [87.12mm]
7"	7.46" [189.48mm]	5.56" [141.22mm]	3.43" [87.12mm]
8"	9.25" [234.50mm]	7.08" [179.73mm]	3.29" [83.57mm]
10"	11.91" [302.41mm]	8.92" [226.48mm]	3.86" [98.04mm]

## Mounting Instructions (6 Inch Model)

The 6-inch models must be mounted using DIN Clips. DIN Clips are metal brackets (P/N EZ-BRK-1, package of 2 brackets and 4 screws) that attach to the panel and secure the front panel to a mounting surface with 4 screws. Use the diagram and instructions below to mount the EZ3 unit using DIN Clips.

1. There are 4 rectangular holes in each side (two at the top and two at the bottom) of the chassis as shown in the following figure. Choose the holes that allow the appropriate space for your mounting panel thickness.
2. On each DIN Clip there are two metal tabs (bent inward) that fit into these holes. Insert the two clip tabs into two holes (top and bottom) and secure the panel by alternately tightening the DIN Clip screws (4) until the back edge of the unit's front plate is flush with the mounting panel.

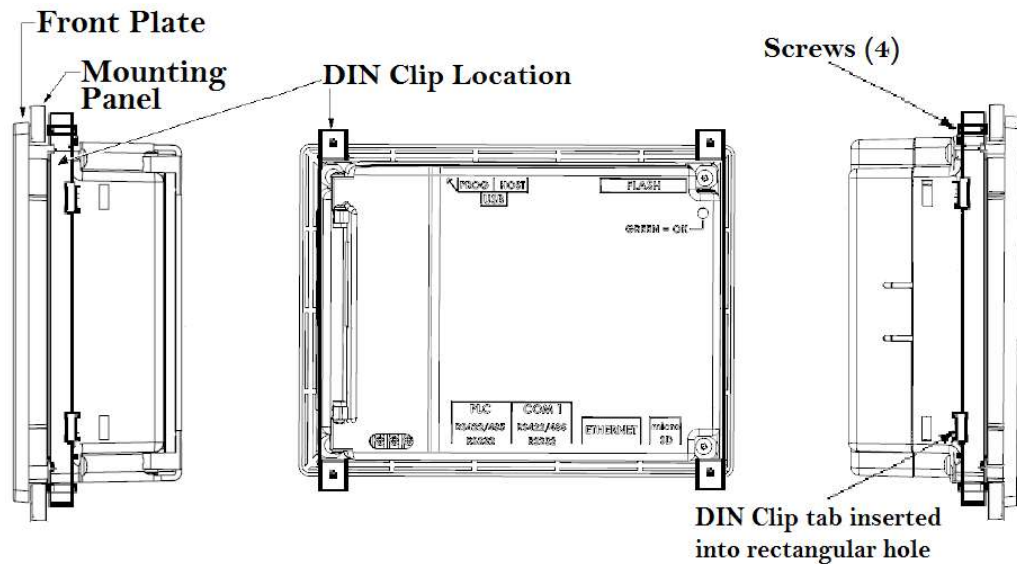

## Mounting Instructions (8 and 10 Inch Model)

The EZ3 is stud mounted. All the necessary mounting hardware is provided with the unit. Use the 8 studs and 8 nuts with captive washers to secure the unit to the mounting surface.

Note: Nuts are to be tightened with no more than 1 inch-pound of torque.

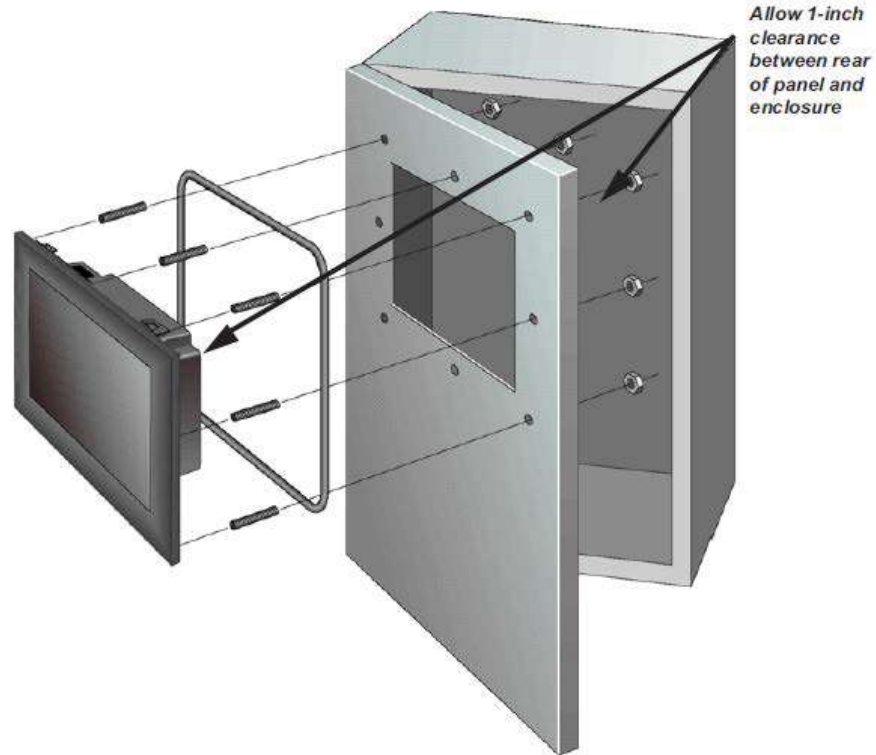

## Powering the Unit

Connect the power input wires into the HMI's power terminals. Supply 24VDC nominal (20-30VDC) power to the system. If the unit does not power up correctly, remove power from the system and check all the wiring. In addition, see the Indicator Light section below for troubleshooting.



## Status LED



LED Behavior	Status Description	Suggested Response
Flashes Red, then continuously Green	Normal Operation	Proceed to use unit
Continuously Red	Unit Failure	Return unit to factory for service
Does Not Light	No Power	Check or Replace 24 VDC Power Supply - if condition continues return unit to factory for service

## Communication and Ports



### PLC Port

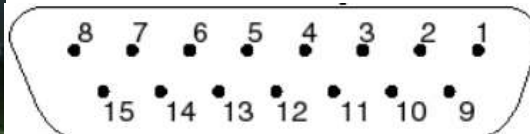

This is the RS-232C, RS-422A or RS-485A female 15-pin D-Sub Connector to connect to other PLCs. Most PLCs connect to the 15-pin D-Sub with a cable specific to the PLC type.

Pin Number	Connection
1	Chassis GND
2	PLC TXD (RS-232C)
3	PLC RXD (RS-232C)
4	+5V (100Ω)
5	Logic GND
6	LE
7	PLC CTS (RS-232C)
8	PLC RTS (RS-232C)
9	RXD+ (RS-422A)
10	RXD- (RS-422A)
11	TXD+ (RS-422A)
12	TXD- (RS-422A)
13	Terminating Resistor (connect to pin 9)
14	NC
15	NC



## COM1 Port

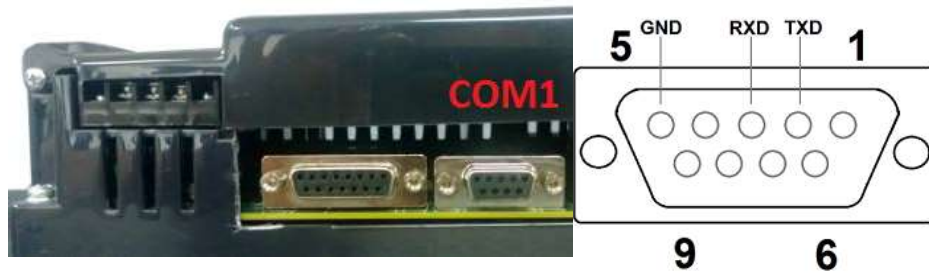

The EZ3 Enhanced Series has a built-in serial port (COM1 PORT) located on the 9-pin D-Sub connector. COM1 PORT is an RS-232 port which requires an appropriate RS-232C cable (**P/N: EZ-PGMCBL**) for programming the unit through a PC. It serves as the default programming port on the EZ3 Enhanced Series. Since COM1 has fixed communication parameters, you can always connect the programming software to the PLC through the port without needing to make different configuration changes. In addition, this connection can be utilized to update firmware when needed.

PGMCBL: Programming Cable Wiring



**CAUTION!** Keep the signal reference GND wire well protected from external noise by using shielded cable.

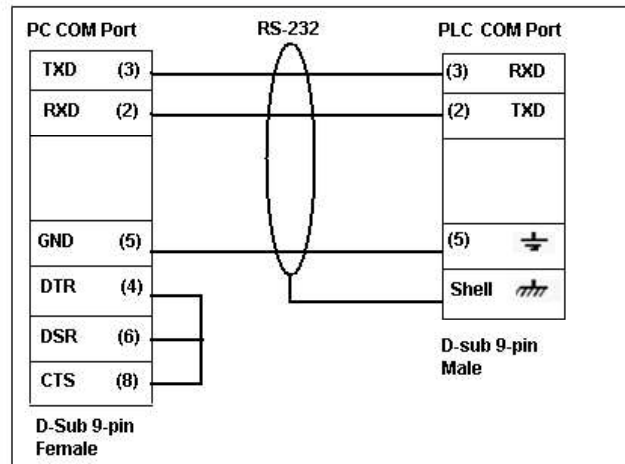

## Ethernet Port



There is an Ethernet port available on the EZ3 Enhanced Series. This port enables users to add/update programming through an Ethernet connection. It allows for both PC and PLC simultaneous communications. It can also be used for Internet access and email alerts.

The following is a list of current drivers supported by the EZ3 Enhanced Series units. We are always updating PLC compatibility, if you don't see your type PLC in this table, visit our web site at [www.ezautomation.net/](http://www.ezautomation.net/) or call EZAutomation technical support at 1-877-774-3259 or FAX at 1-877-775-3279.

### EZTouch and EZTouch I/O Supported Drivers:

**Allen Bradley:**

A-B DF1 Half and Full Duplex (PLC-5, SLC500, Micrologix 1000, 1200 and 1500)  
 AIC/AIC+ for Micrologix 1000, 1200,1400, 1500,SLC 500, 5/01, 5/02, 5/03)  
 A-B Micrologix 800 CIP Protocol  
 A-B Ethernet I/P (MicroLogix 800, Control & Compact Logix)  
 A-B DF1 over Ethernet (for Micrologix & SLC 500 PLCs)  
 A-B Data Highway Plus (DH+)  
 A-B Remote I/O

**Automation Direct:**

ADC K-Sequence (Direct Logic PLCs)  
 DirectNET (Direct Logic PLCs)  
 Do-More PLC (Serial & Ethernet)  
 Modbus (Productivity 3000 PACs, Direct Logic PLCs, Click PLCs)  
 ECOM Ethernet (Direct Logic PLCs)  
 Entity Think&Do (Modbus RTU and Modbus TCP/IP)  
 Productivity Driver (Serial & Ethernet)

**ABB:** (COMLI Driver)

**All Motion:** (EZ Stepper)

**Animatics:** (Smart Motor)

**Applied Motion:** (SCL series)

**GE:**

GE Fanuc SNPX (90/30, 90/70)  
 GE SRTP over Ethernet

**IDEC:** Computer Link

**Keyence:** (CV 5000)

**Mitsubishi:**

FX Series CPU (Computer Link)  
 FX-1N(C), 2N(C), 3(U) CPU  
 Q Series PLCs  
 A Series PLCs  
 Mitsubishi CC Link  
 Melsec FX

**Modicon / Schneider:**

DeviceNet  
 Modbus RTU  
 Modbus TCP/IP  
 Modbus Plus (Industrial Network)  
 Uni-Telway

**Omron:** Host Link Adaptor

**Siemens:**

S7 (Serial:PPI)  
 Siemens Ethernet ISO over TCP/IP  
 S7-200, S7-300, S7-400, S7-1200 & S7-1500 series  
 ProfiNet  
 Profibus

<p>Aromat: (Mewtocol)</p> <p>AVG / EZAutomation: EZPLC EZ Ethernet</p> <p><b>Baldor:</b> (Host Comms)</p> <p><b>Bristol Babcock:</b> BSAP Native (serial)</p> <p><b>Control Techniques:</b> Unidrive 2-wire, 4-wire (binary)</p> <p><b>Control Technology Corp (CTC):</b> CTC 2600, 2700 and 5100 (CTC Binary)</p>	<p><b>Texas Instruments (TI):</b> TI 5x5 series, TI 505, TI 545-1102, TI 545-1104</p> <p><b>Square D:</b> Square D Symax – 300 Series CPU, 400 Series CPU</p> <p><b>Yaskawa:</b> Memobus Native Addressing Memo-bus RTU</p>
--	---

## Micro SD slot



A Micro SD slot is available to allow for additional storage or data transfer. Insert a Micro SD into the slot and it will load automatically. Additional details about using a MicroSD Card for data logging is available in the [Data Logging Overview](#) section. When finished, push against the Micro SD card to eject it.

**Note:** The Micro SD and USB flash drive cannot be used to log data simultaneously.

## Network Option Cards

Depending on model purchased, a network option card is also available for additional connectivity. EZ3 Enhanced Series units ending in -EH come equipped with a DataHighway Plus / Remote IO option card.

## USB Ports

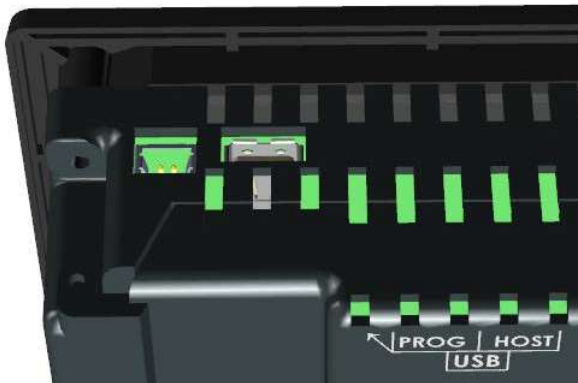

### Dual USB Ports

EZ3 Series HMIs come equipped with two USB ports. The port on the left is for program upload through a USB A to USB B programming cable.

**Note:** If a powercycle occurs while the USB programming cable is connected, the cable will need unplugged and then replugged in to reestablish a connection.

The Host USB port (on the right) can connect to a USB Flash drive for program upload by simply using our EZTouch Editor Software to create a USB Loader file (.hmi). This process benefits system integrators and OEMs by permitting them to upgrade panels on site without the need to connect to a computer. Please see our EZTouch Editor Software Help for detailed instructions on this process. In addition, the Host USB can be utilized for data logging purposes in combination with our AVG Remote File Manager Utility.

**Note:** The Micro SD and USB flash drive cannot be used to log data simultaneously.

## Programming the Panel

### Create a Project

This section outlines the basics of creating a project using the EZTouch Editor software. Further programming information for the EZ3 Series is located in the Software Manual.

Launch your Programming Software and select how you would like the program to link to the Windows HMI unit. For this scenario, you can select 'Edit Program OFF-LINE.' This will enable you to create a program without having the Windows HMI unit connected.

**NOTE:** EZ Series Editor must be version 6.1.11 or later to communicate with the EZ3 Series. Unit firmware must be k.5.35 or later. 7" HMI requires EZTouch Editor v2.0 to program the Unit.

1. Enter a project name (e.g. Test). Click OK.

2. Under Panel Family, select EZ3 Series. Then select the size appropriate for your purchased unit (6", 8" or 10").

- Next, select the PLC Manufacturer and protocol you would like to use with the unit.  
(Example shown below.)

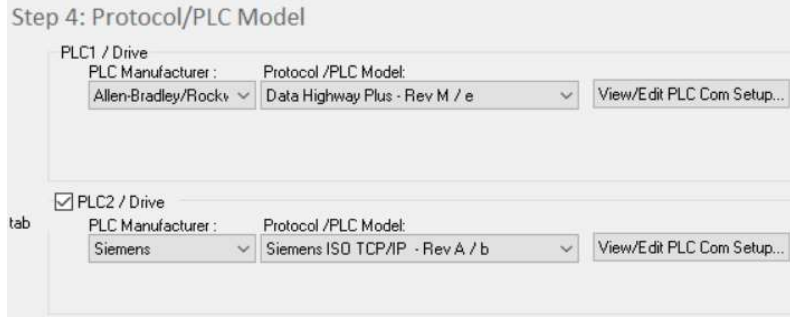

- Click OK to launch the editing software program. The Main Project Window will then appear. The steps below outline how to create a sample panel program.

**Create a Panel Program:** Click on “Panel” and "Scr 1" to create the Panel display screen as explained in the sample below.

- In the Main Menu, click on **Objects > Buttons > Buttons**. The screen below will appear. Enter **START** for Tag Name. Click OK.

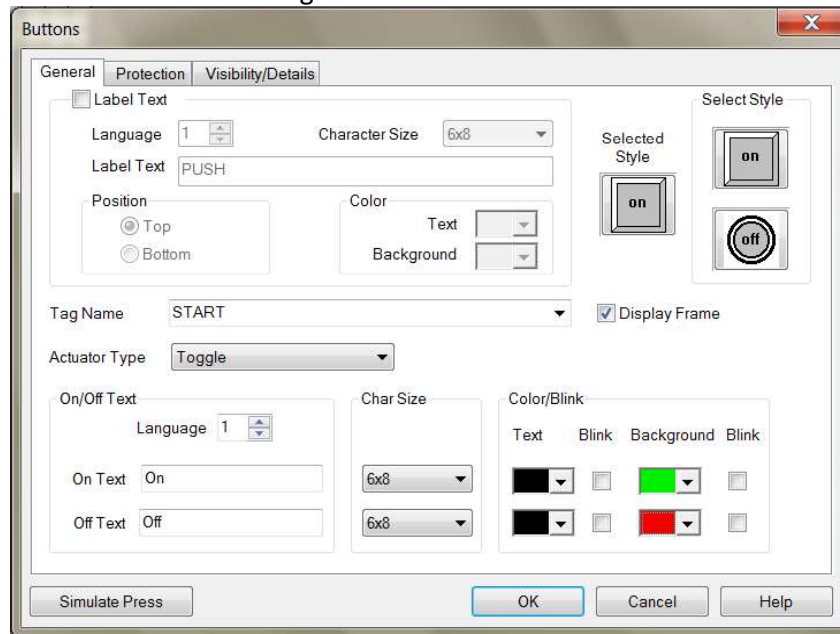

- A dialog box might appear requesting the memory location. Enter "S1" in the field to the right of "Address String." The Data Type should be marked as DISCRETE. Click OK.

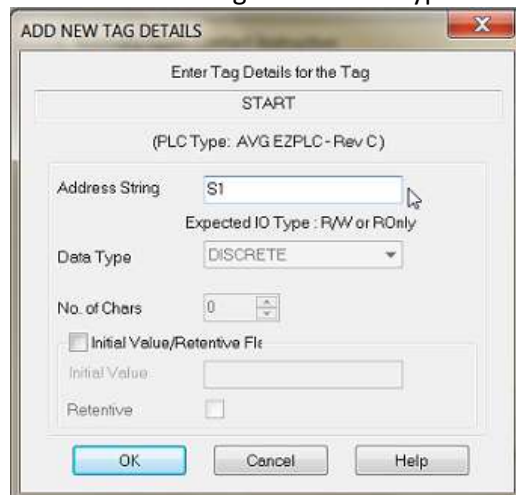

3. Click anywhere on the screen to place the Button object. Double click the icon to open its object dialog box if you need to adjust the object's appearance or attributes. Clicking "Simulates Press" will allow you to toggle between On and Off states.

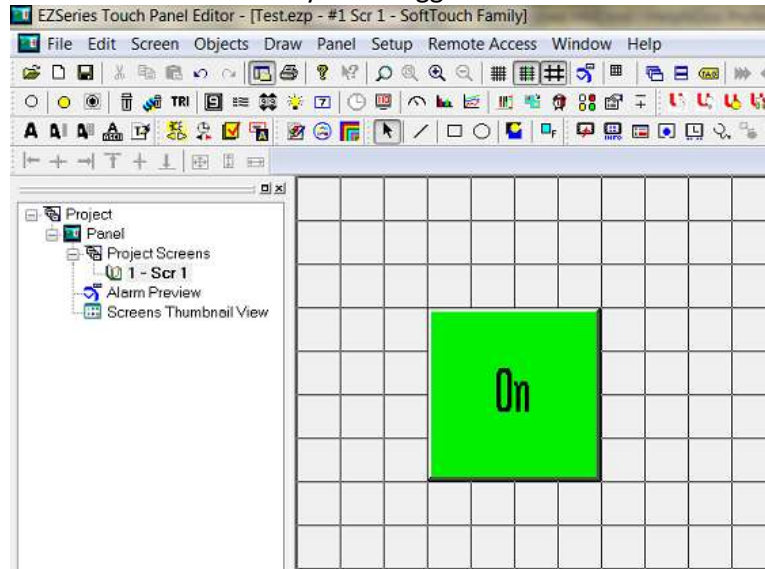

4. Similarly, you can create an Indicator Light Object by selecting **Objects > Data Display > Indicator Light**. Enter **Lamp** for Tag Name. Click OK. Place the object on the panel. Your screen should look like the picture below.

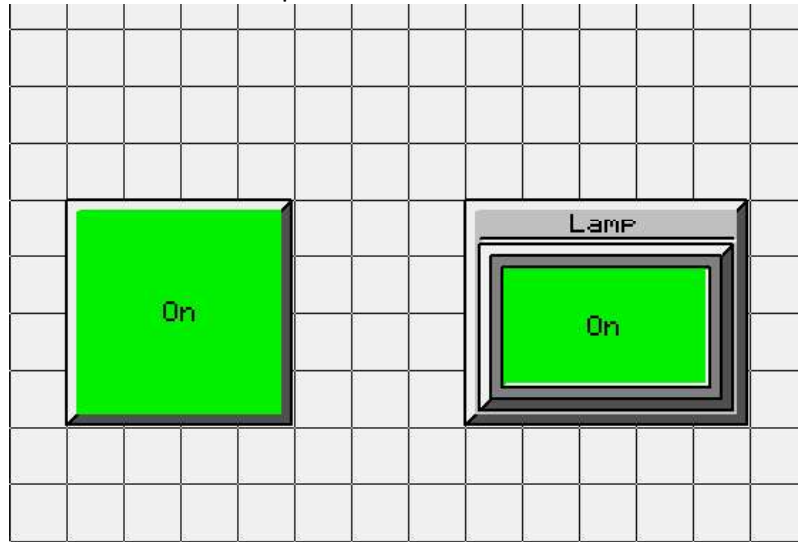

## Transfer a Project

After a project is complete, the next step is to transfer the project to the EZ3 Series unit. When editing projects online, programming information is automatically sent to the unit once the project is saved. When editing in an off-line mode, the project information will need to be transferred. To transfer the project through the serial connection or Ethernet port, follow the steps outlined below:

From the Project drop down menu, select **File > Transfer to Panel**. A dialog box similar to the one below will appear.

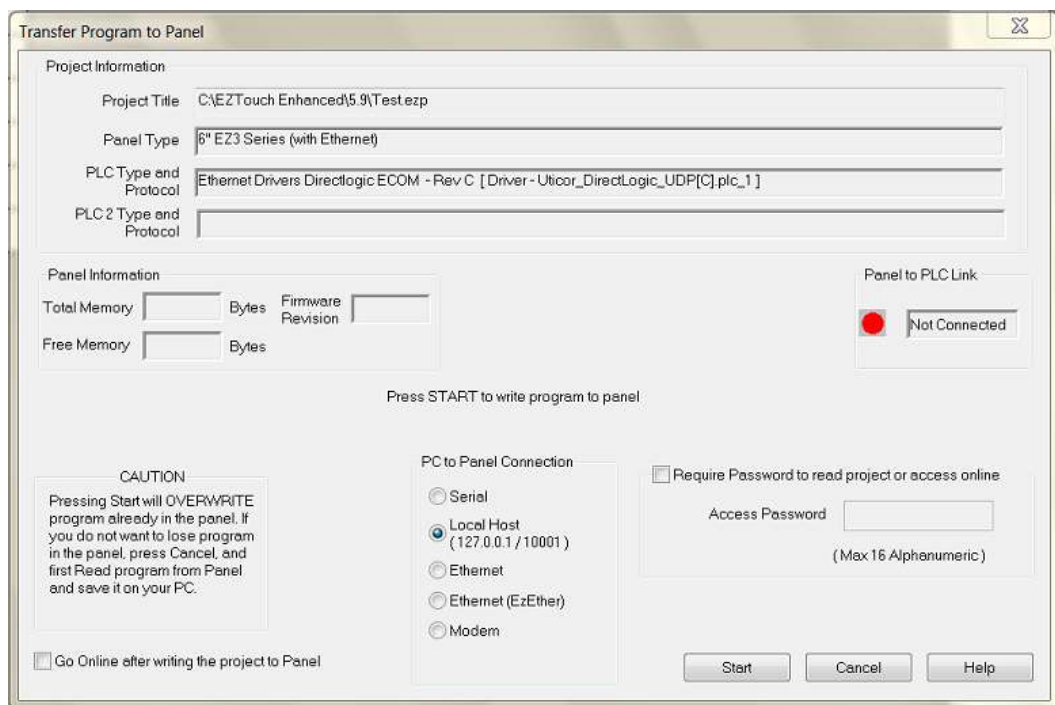

If transferring serially:

1. Verify the RS-232C cable (**P/N: EZ-PGMCBL**) is connected between the unit and the PC. In the absence of an RS-232 port on the PC, a USB to RS-232 converter may be used to connect the programming cable to the PC.

**Note:** The recommended USB to Serial converters are ATEN-UC-232A or Belkin-F5U409.

2. Select *Serial (COM1)* as method of transfer under PC to Panel Connection. And then click *Start*.

If transferring via Ethernet:

1. Select Ethernet as PC to Panel Connection.

**Note:** Click the *Specify IP/Port* button in order to make adjustments to the IP Address or Port.

2. Then click *Start*.

When finished, a Transfer Completed message will be displayed. Click OK to continue and the project is now transferred.



## Data Logging Overview

The EZ3 Panel offers a flexible Data Acquisition capability. You can acquire and save the data for one or more tags defined in the panel. The acquired data along with a time stamp is saved in CSV file format in the USB stick or the MicroSD card, depending on how the schedule is set.

Schedules determine the way data will be collected. For example, data can be collected every 10 seconds, or simply at a specific time such as 9 AM, or when a certain event takes place. The user can define one or more schedules as long as each schedule is unique. (For example, there cannot be two schedules that each collect data every 30 seconds.) User can also associate a name (up to 8 characters) with each schedule. Each schedule can be used to collect data for up to 32 tags.

## Adding a Schedule

1. Open your project file for the EZ3 using the EZ Series Touch Panel Software.
2. Then click **Setup < Data Acquisition** to display the DAQ Schedule dialog.

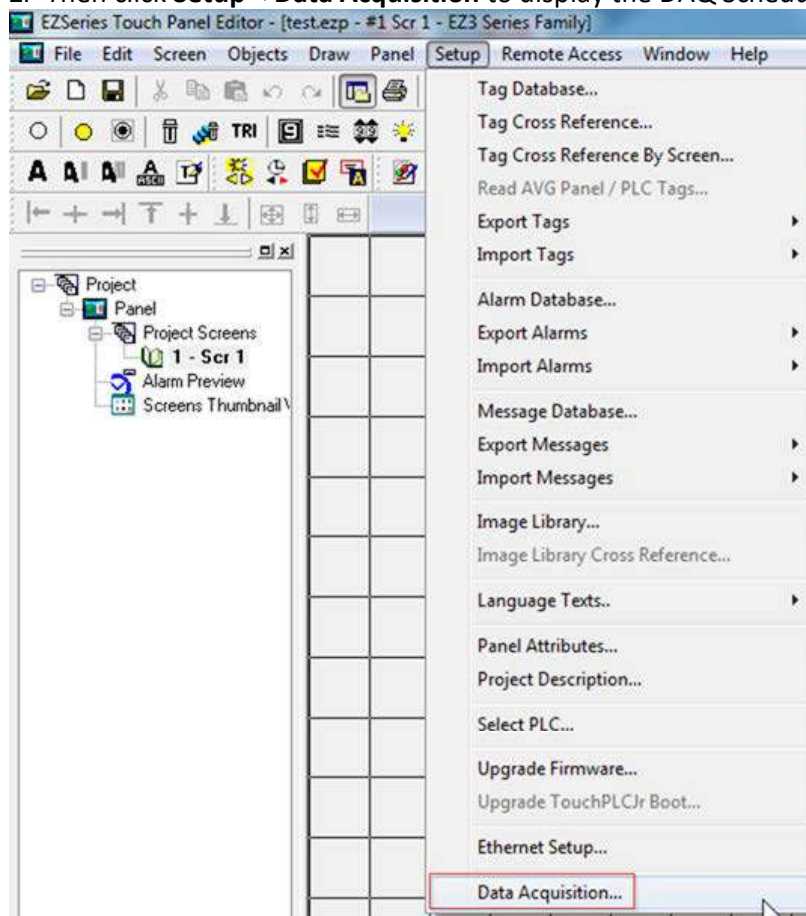

3. The Data Acquisition dialog box will appear. This dialog box allows you to add the new schedules and edit/delete the existing ones.

**Please note:** User must select either USB or Micro SD as a data-logging option (shown below).

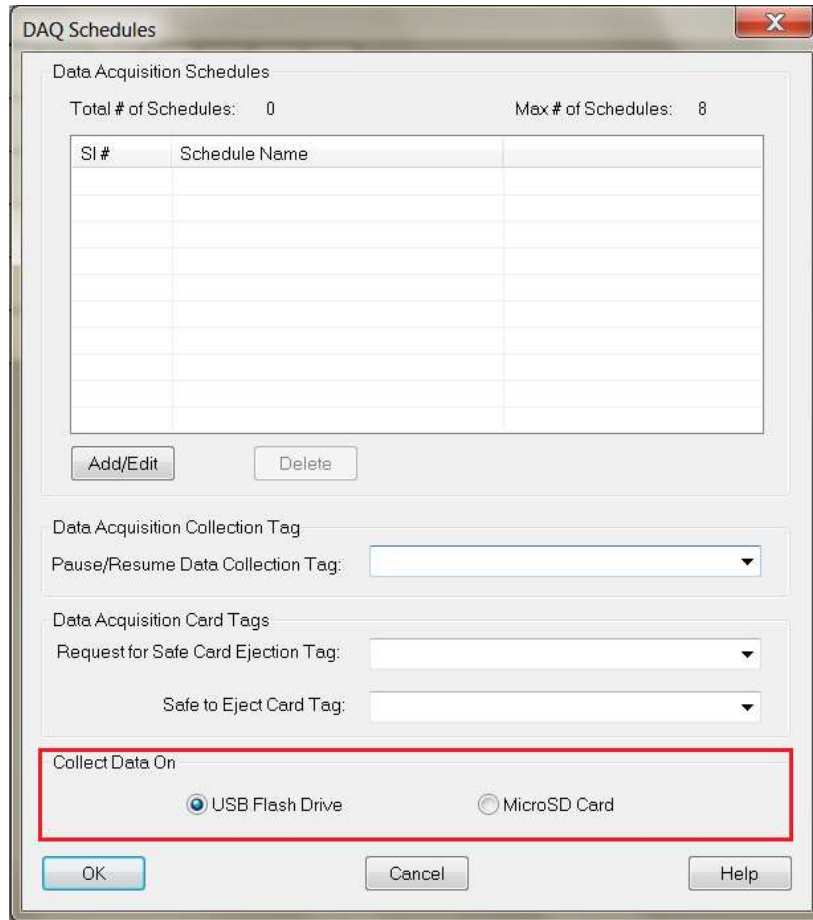

- Click on Add/Edit button to display the "Add DAQ Schedule Details."



- The "Add DAQ Schedule Details" box will appear allowing you to create a new schedule for the panel. Schedule names can be either tag based or a Constant (user defined name).

**Note:** Tag based file names can be changed on the panel itself at any point.

- Select a Schedule Type. (Details on schedule types provided below.)
- Under "Select Tags for Data Acquisition," the selection displays all the tags defined in the panel with their corresponding tag addresses. To select a tag for data acquisition, click on it and then press the >> button. To deselect the tag for data acquisition, select it again and press the << button. Maximum tags per schedule is 32.

**Note:** Tags can also be selected or deselected by double-clicking on them.

- Click "Add" when finished and then click "Close" to return to the main DAQ Schedules dialog box.
- The added schedules will now be listed. Schedules are saved along with the user project.

## Types of Schedules

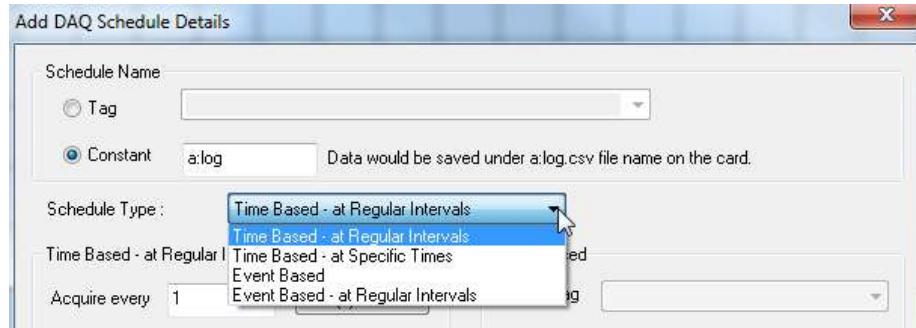

### 1. Time based – at regular Intervals

Allows you to store the tag value at regular time intervals, anywhere from every 1 second to every 1000 hours.



### 2. Time based – at Specific Times

Allows you to store the value of a group of tags up to 10 specific times. You may always edit / delete a specified time.

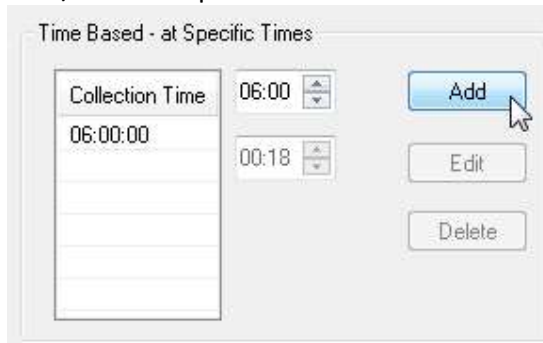

### 3. Event Based:

Allows you to create an event and store the values of a group of tags on the occurrence of the same. Based on the data type of the event tag, schedule can be either Discrete Event Type or Numeric Event Type.

#### Discrete Type Event:

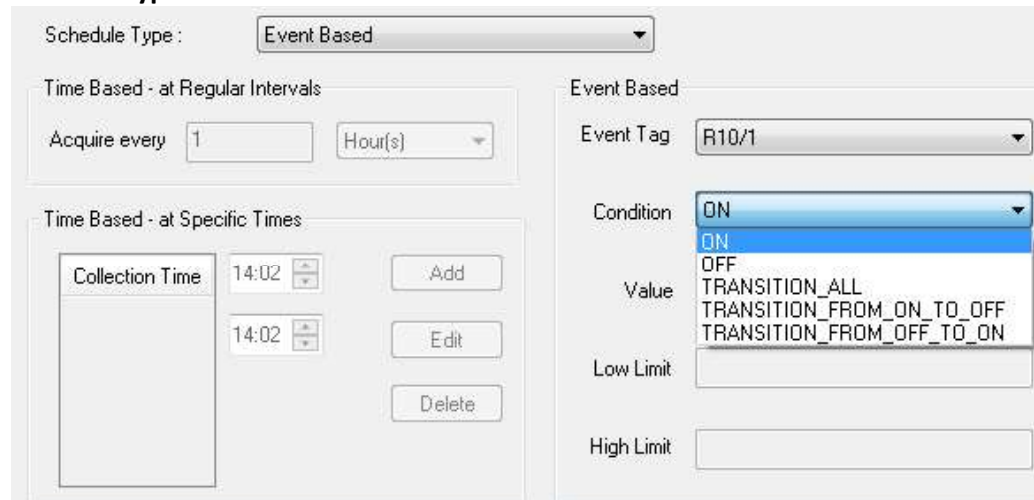

**Numeric Type event:**

**4. Event Based - at Regular Intervals:**

Allows you to create an event and store the values of a group of tags on the occurrence of the same during a set time period. Based on the data type of the event tag, schedule can be either Discrete Event Type or Numeric Event Type.

- a. Set how frequently the data is stored through the Time Based interval, anywhere from every 1 second to every 1000 hours.

- b. Select either a Discrete Type Event or a Numeric Event Type.

**Discrete Type Event:**

**Numeric Type event:**

## Pausing Data Acquisition and Ejecting Card

### Pause / Resume Data Collection Tag:

This is a discrete tag that can be controlled by user (e.g. through a Push Button) or by PLC to enable or disable data acquisition. When the tag's value is 0, data collection is enabled; and when it is 1, the collection is disabled or paused. Setting the tag to 0 resumes the data collection.

### Request for Safe Card Ejection Tag:

This is a discrete tag and can be controlled by user or PLC. The Tag is set by user (say by a Pushbutton) or by PLC to indicate that the user would like to remove the SD card for possibly reading it in a SD card reader. When Panel sees this tag as set, all buffered data is written to the files, and files are closed for safe removal of the card. Another discrete tag, Safe-to-Eject-Card is set to indicate that it is now safe to remove the SD card without fear of file corruption. At the same time, the Request tag is reset by the panel.

**Safe to Eject Card Tag:**

This is a discrete internal tag. The tag must not be mapped to PLC. The Panel would set this tag when it is safe to remove the card. It is reset whenever it is unsafe to remove the card. **It is highly recommended that you use Request-for-Safe-Card-Ejection and Safe-to-Eject-Card tags for removing the card. If the card is removed without safe indication, the data on the card may get corrupted due to open files.**

**Changing logging between USB and Micro SD**

There are two options to change how the data logging information is saved.

**Option #1** Using the Programming Software

1. Open your project file for the EZ3 using the EZ Series Touch Panel Software.
2. Then click **Setup < Data Acquisition** to display the DAQ Schedule dialog.
3. Select either USB Flash Drive or MicroSD card.
4. Click OK and then save the project.

**Option #2** On the EZ3 panel

1. Simultaneously press the upper left corner and bottom left corner of the screen for the EZ3 unit that has the program downloaded.
2. After selecting the appropriate language for the unit, the unit will enter the Setup Mode (shown below). Press the "LogtoSD" button to change how the data is logged.

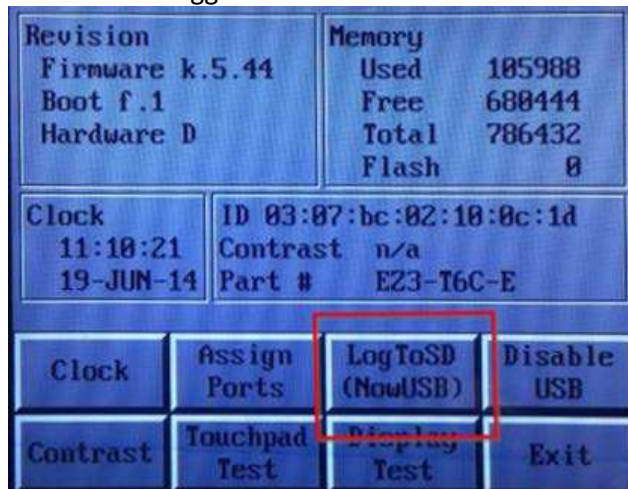

3. When finished, press Exit to resume normal operations.

## Create OEM Packager

The **EZPackager utility** allows an OEM to distribute updates to EZSeries Touch Panel or EZPLC projects easily and quickly. Using the utility, OEMs can package current project and/or firmware into a zip file for distribution to the end user via email or the web. If you click on **File > Create OEM Package**, it will allow you to package the current **EZPanel** or **EZPLC project** and/or the **firmware** into a zip file called a **pack file** for the distribution purposes.

**Benefits of the utility include:**

- OEMs save costs associated with the distribution of panel updates in the field (sending field service personnel or mailing CDs).
- OEM Projects are protected since end users cannot modify the projects.
- The end user benefits from convenient, fast and easy updates without needing to purchase the EZSeries Touch Panel Editor software.

**Creating a Pack File:**

1. Use the EZ Series Editor Software to open the project you wish to distribute.
2. Click on **File > Create OEM Package**. A dialog box similar to the one shown below will appear. Select what firmware you wish to include in the zip file. (Use Browse to locate the latest firmware versions if necessary.) Enter any necessary OEM information you wish to include in the fields provided.

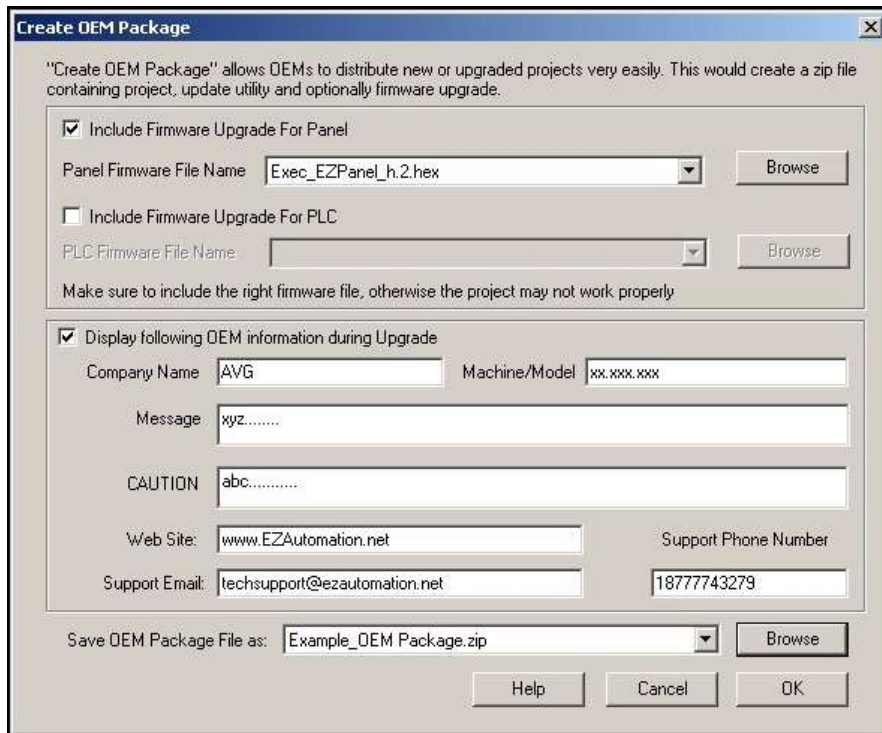

3. Use **Browse** to determine the file save location and OEM package name. Then click **OK**.



### Opening a Pack File

A Pack File contains the following:

1. Updater application (comprising of the .exe and required dlls)
2. Project files (which would show up inside the Project folder when unzipped)
3. Firmware files (which would show up inside the Firmware folder when unzipped)

The end user can take the pack file, unzip it, and then run the EZSeries Touch Panel Updater application to update his/her panel with the selected project(s) and/or firmware. To open a pack file, follow the steps below:

1. Click on the zipped OEM Package file that you have. It contains EzUpdate.exe (Ezupdater MFC application) and example.pkg (PKG File). Extract these file in a folder of your choice.

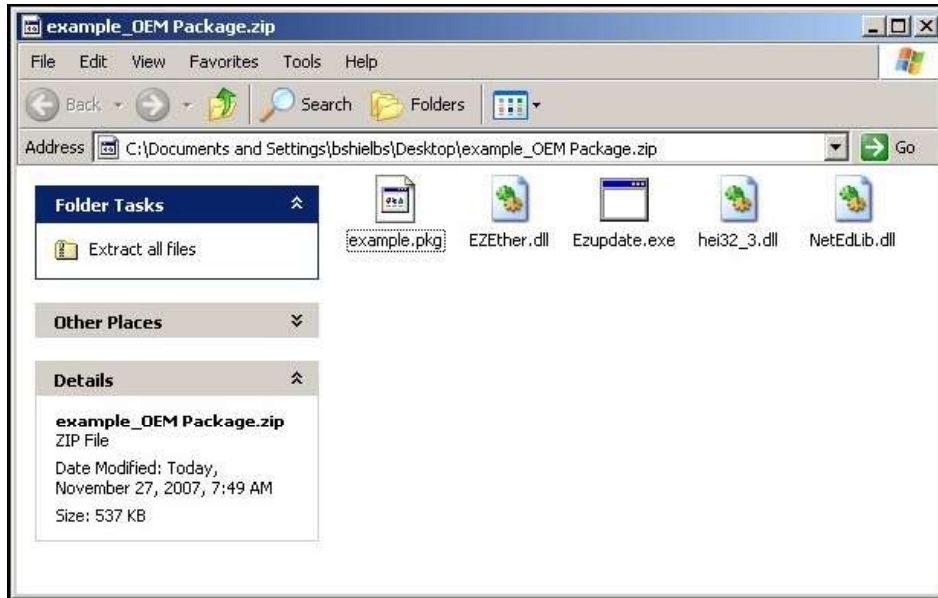

2. In this example, files have been extracted in a folder named as **example\_OEM Package**.

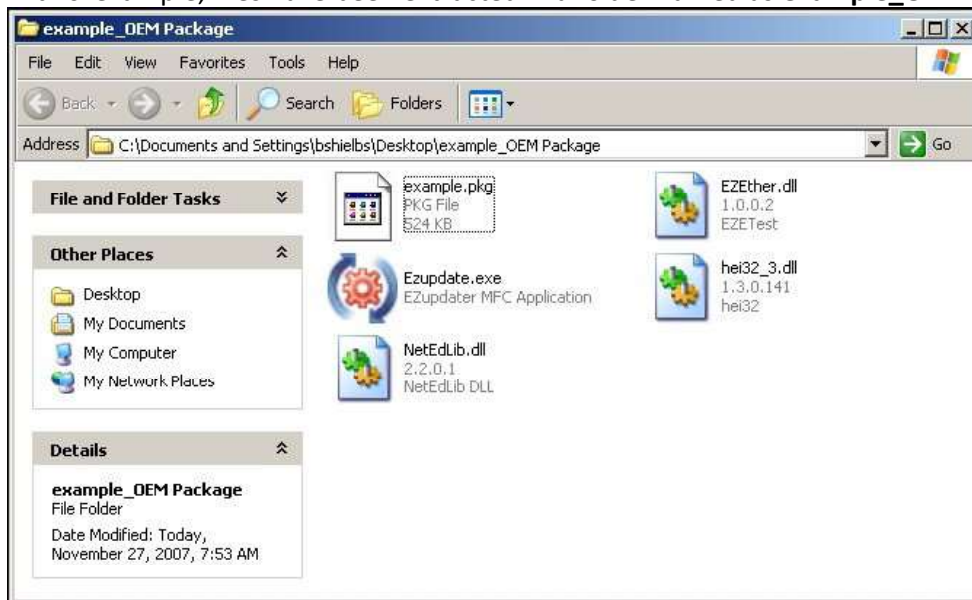



- Click on the **EzUpdate utility** for the following dialog window. Browse and select the **Package File** to be used for **updating the project** and/or **firmware**. Then click **OK**.

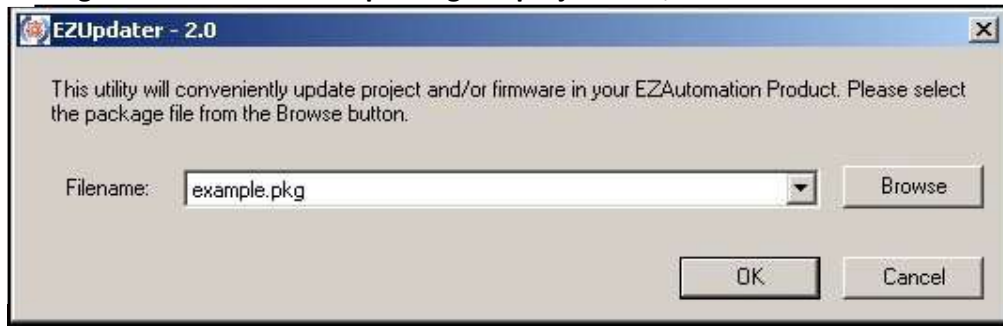

- Once you click on **OK**, EZUpdater window appears on the screen with an option to select the communication port. You may also test the connection, before a final click to Update button. Click on the **Update** button to update the Project and/or the Firmware on your EZSeries TouchPLC.

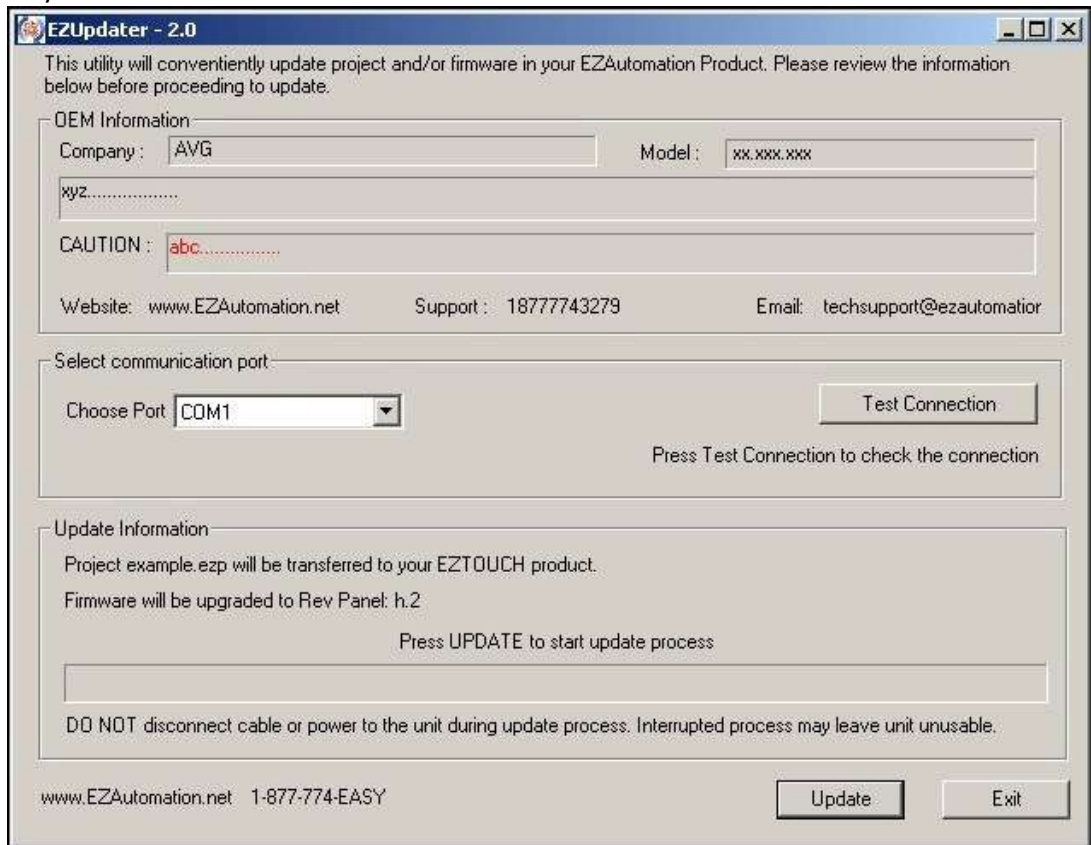

## Create USB Loader

Through the EZ Series Editor Software (version 5.5 and higher) users can program EZ TouchPLCs through a USB Flash drive. This process especially benefits System Integrators and OEMs with upgrading the Panels on-site without having to actually connect to a computer. Since multiple programs can be saved on one USB Flash drive, the user can program different panels with the same USB Flash drive, or quickly change the Panel for different jobs.

The EZ TouchPLCs can be programmed in following easy steps:

1. Create a USB file (\*.hmi) using the EZ Touch Program Loader.
2. Save the file on the USB Flash drive (only in the root directory).
3. Insert the USB stick into the EZ TouchPLC's USB port.
4. The panel brings up a list of projects that are available on the USB Flash drive. Select the necessary project and press OK. (If the panel is not compatible with the project selected, an Error message is displayed.)
5. The project is automatically loaded on the EZ TouchPLC.

### Creating files for use with USB Flash Drive

In the EZ Series Editor's main programming window, click on menu **File > Create USB Loader** to create user project file for use with the USB flash drive. User can select name. The file is saved with .hmi extension.

The dialog box shown below would appear:

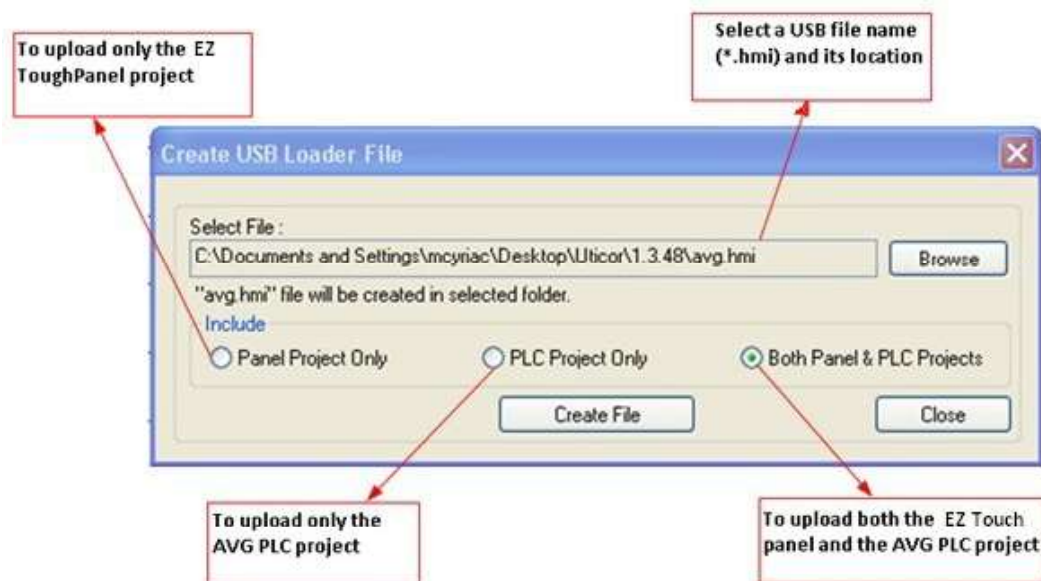

### **Copy file(s) on USB Drive**

Copy file(s) created by the editor on the root directory of a USB flash disk. (Please note files copied in a location other than root directory would not be read by the panel.) All files are saved automatically with .hmi extension. Files without this extension will not be read.

### **Programming the panel using USB Drive**

To program an EZ TouchPLC from USB Drive, insert the USB flash directly into the EZ TouchPLC's USB port. The panel would display a list of files available in the root directory (with .hmi extension). An example is shown below:

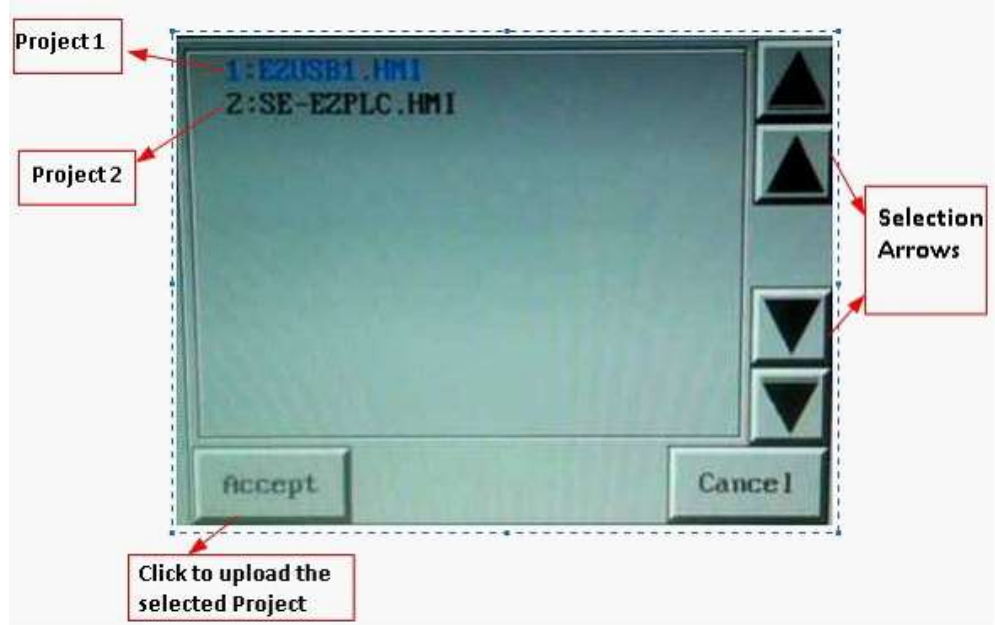

Select the required project using the Up-Down arrows and press "Accept." If the panel is **not compatible** with the project selected, an Error message saying "Wrong panel Type" is displayed. The selected project is then automatically loaded into the EZ TouchPLC.

## Remote Monitoring & Control

With the introduction of new **Remote-Access Card** and **Remote Monitor & Control (RMC) Software** EZSeries TouchPLCs offer a unique set of remote capabilities. A user can remotely log on to a unit and monitor any of the panel screens with live data including the currently displayed screen.

With the right access permissions and authentication, a user can remotely "touch" objects on the panel, to control a machine/plant effectively. Remote control feature can be invaluable for remote diagnostics, unmanned operations, or supervisory monitoring.

In addition to remote monitoring and control, user may also program the panels remotely over Ethernet, allowing OEMs to remotely upgrade the screen programs within the panels.

For Remote Monitoring and control we need to follow these steps:

1. Use EZ Touch Panel editor to set up IP address of the panel.
2. Use EZ Touch Panel editor to set up remote users and authentication level.
3. Use RMC (Remote Monitoring & Control) software to connect to the panel remotely.

### Setting up Remote Users

The EZ-RMC Software can be used with or without defining authorized users. If you don't define any remote users, then anyone can connect to the panel using EZ-RMC Software. However they can ONLY VIEW the panel screen; they would not be able to make any changes to the panel. ***It is highly recommended that you do define authorized users for remote access.***

Remote users can be given View ONLY or Operation (View + Control) permission. View only permission allows user to ONLY monitor the panel display remotely, while operation permission allows a user to operate panel remotely.

Select **Remote Access > Remote Users** as shown below to display the following EZ-RMC User Dialog window

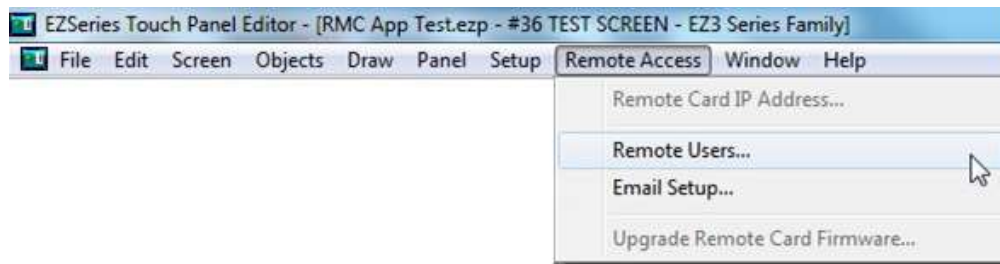

**Set Remote Users**

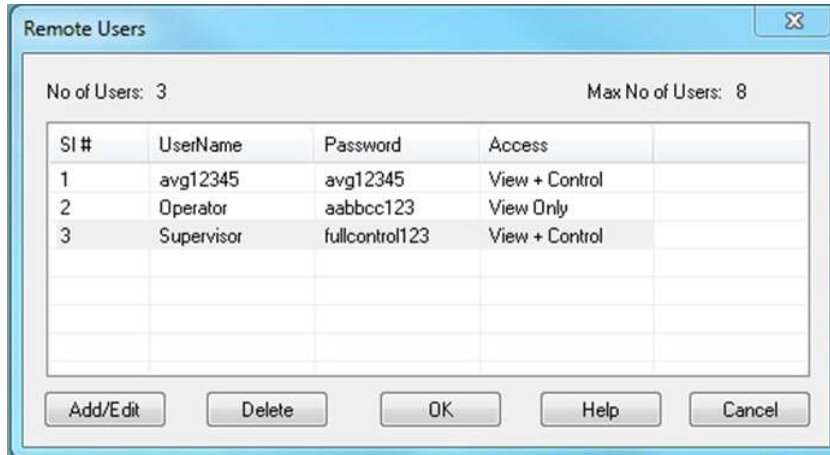

Here you may add up to 8 remote users by clicking on Add/Edit button. The Log-in name and the password are case sensitive and both must be between 8 to 16

characters in length. Password also must contain at least one letter and one number.

**Add/Edit Remote Users**

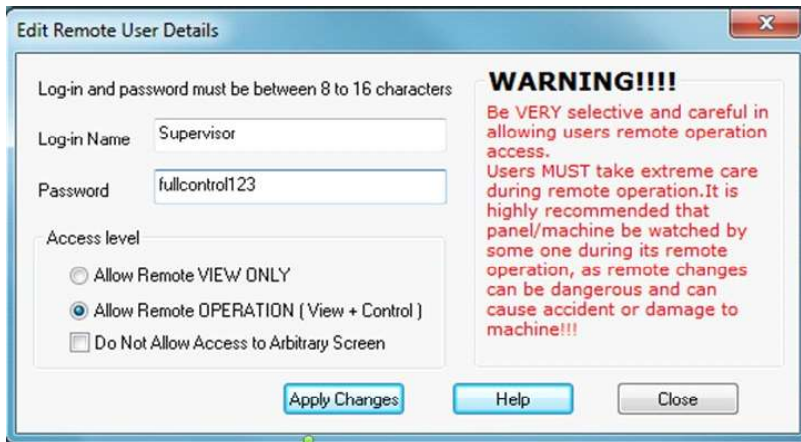

To edit the information of an existing user, please select the appropriate row and click on Add/Edit button. It will bring up the information of the selected user in edit mode.

**Access Level**

- **ONLY Remote VIEW** - A user can remotely log on to the panel and monitor any of the panel screens with live data including the currently displayed screen.
- **Remote OPERATION** - A user can remotely log on to the panel and monitor any of the panel screens with live data including the currently displayed screen as well as can remotely "touch" the objects on the panel, to effectively operate or control a machine/plant.

**WARNING!!!**

Be VERY selective and careful in allowing users remote operation access. Users MUST take extreme care during remote operation. It is highly recommended that panel/machine be watched by someone during its remote operation, as remote changes can be dangerous and can cause accident or damage to machine!!!

## Run RMC Software

To access the panel over Ethernet, you need to install and run the EZ-RMC software on your PC. Once you run the software, you will see the following EZ-RMC dialog.

### Select Parameters

The dialog box titled "EZ-RMC 0.99.25" contains the following fields and controls:

- Ethernet/COM Port:** A dropdown menu with "Ethernet" selected.
- Select Ethernet/COM Port:** A label for the dropdown menu.
- IP Address:** A text box containing "10 . 1 . 200 . 26".
- Port Number:** A text box containing "10001".
- Polling Time:** A dropdown menu with "100 msec" selected.
- Buttons:** "OK" and "Cancel" buttons at the bottom.

Select the communication port, IP Address if Ethernet is selected, and Polling Time. The IP Address is the IP Address of the RMC card you setup earlier. It is recommended to keep polling time as high as possible. **Polling time** determines how often RMC software would read information from the panel. A lower polling time may impact the performance of the panel.

### Remote User

The dialog box titled "Authentication Information" contains the following fields and controls:

- User Name:** A text box containing "Andrew".
- Password:** A text box with masked characters "\*\*\*\*\*".
- Buttons:** "OK" and "Cancel" buttons at the bottom.

Clicking OK will prompt you to provide user name and password, if at least one remote user has been set up. **Please note that both user name and passwords are case sensitive.** If no remote users were defined, this dialog box would not appear.

### Access Password

The dialog box titled "Enter Access Password" contains the following fields and controls:

- Message:** "Password is required to read project:"
- Access Password:** A text box with a masked password "\*\*\*\*\*".
- Buttons:** "OK" and "Cancel" buttons at the bottom.

Projects requiring an Access Password will need the access password entered before the user information. You must have a correct Access Password in order to communicate with the panel. This is project level password set during screen design under **Setup > Panel Attribute >**

### General Tab.

## Maintenance and Troubleshooting

---

### Hardware Maintenance

Routine maintenance checks should be performed on the unit to avoid any risk of hardware problems. The EZ3 Series is designed to be a very rugged controller so that just a few checks periodically will help keep it up and running.

The key points to be checked include:

- Ambient operating conditions
- Wiring and connections

### Maintaining the Ambient Operating Conditions

Keeping the EZ3 Series unit's environment within specified operating conditions is the best method to minimize the maintenance.

1. Always ensure that ambient temperature inside the cabinet is within EZ3 Series unit's temperature ratings.
2. If any other equipment inside or outside of the cabinet is producing heat, employ cooling methods like a blower fan to reduce 'hot spots' around the EZ3 Series.
3. Periodically inspect and clean if there are any air filters on the cabinet. Ensure that the unit is free from dust, humidity and corrosive gases.

## Changing the Battery

The unit comes with a built in Lithium battery with a 5 year life expectancy. The steps below outline the process to change the battery inside the unit. Since only the information saved to the registers/discretes available on a power cycle will remain intact, please save pertinent information before attempting to change the battery. Then remove power from the unit.

1. Open the back cover to access the battery.



2. The battery is located in the upper-left hand corner as shown in the figure below. Remove the old battery and replace with a new 1/2 AA, 3.6 V Lithium Battery (Part Number: **EZ-BAT**).



3. Close rear cover and ensure that the door latches.
4. Reconnect power source. Connect to PC and run the Programming Software to transfer back the user program to the EZ3 Series.

The Real Time Clock (RTC) will need reset after the battery has been replaced. All information saved to the registers/discretes available on a power cycle will remain intact. Data not saved to registers/discretes available during a power cycle will be lost.



## Update Firmware

- 1 Insert a RS-232C cable into the COM1 port and launch the EZ Panel Editor software.
- 2 Select Edit Program ON-LINE and enter a project name (e.g. Test). Click OK.

ENTER PROJECT INFORMATION

Project Location : \\Avgapp1\Profiles\cspiner\Utico\r\'

Project Name : Test

- 3 Under Panel Family, select EZ3 Series. Then select the size appropriate for your purchased unit (6", 8" or 10").

Select EZSeries Panel

Panel Family: EZ3 Series

Size:  4"  6"  8"  10"  15"

- 4 Next, select the PLC Manufacturer and protocol you would like to use with the unit. (Example shown below.) Then click OK.

PLC

PLC Manufacturer : Ethernet Drivers

PLC Model and Protocol : Directlogic ECOM - Rev C / C

- 5 After the project loads, click **Setup > Upgrade Firmware**. A dialog box will appear requesting the firmware file you would like to load to the unit.

Setup Remote Access Window Help

- Tag Database...
- Tag Cross Reference...
- Tag Cross Reference By Screen...
- Read AVG Panel / PLC Tags...
- Export Tags
- Import Tags
- Alarm Database...
- Export Alarms
- Import Alarms
- Message Database...
- Export Messages
- Import Messages
- Image Library...
- Image Library Cross Reference...
- Language Texts...
- Panel Attributes...
- Project Description...
- Select PLC...
- Upgrade Firmware...**
- Ethernet Setup...
- Data Acquisition...

- 6 Use *Browse* to locate the appropriate firmware version.

Select firmware file for upgrading panel

The firmware upgrade file is usually named as Touchpanel(\_Jr)\_xx.hex (xx being the firmware version, eg. H.0 and Jr for specifying TouchPanelJr Panel Firmware files). Please select Touchpanel(\_Jr)\_xx.hex (or the file under which you have saved the firmware upgrade file)

C:\EZTouch Enhanced\5.9\Firmware\Touchpanel\_Jr\_K\_2\_85.hex

Firmware Location

Firmware is generally stored under following directory:

C:\EZTouch Enhanced\5.9\Firmware\

7 Verify Serial (COM1) is selected under the PC to Panel Connection, then click OK.

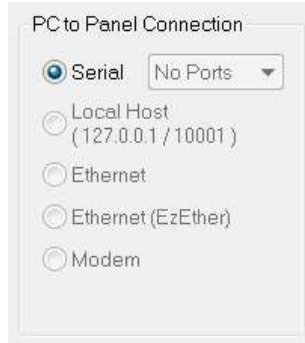

## Troubleshooting

If you encounter difficulties while using our EZ3 Series device, please consult the table below. Additional assistance is also available within the **EZ Panel Enhanced Software Help**. Alternatively, you may also find answers to your questions in the operator interface section of our website @ [flash.ezautomation.net](http://flash.ezautomation.net).

Problem		Possible Cause	Suggested Action
<b>Operation</b>	Status LED is off	Disconnected or faulty power source	Check and repair power source.
			Check the wiring for loose contacts and secure them if found.
			Ensure that proper polarity is observed.
		Input power level is outside of unit's power rating specifications	Ensure that the power being presented to the PLC terminal is within the <a href="#">specified range</a> .
	Status LED is red	Unit Failure	Power cycle the PLC once to see if an intermittent high frequency noise has caused the failure.
			If problem persists, call AVG Automation for assistance.
<b>Communication</b>	No communication with unit	Disconnected or loose cable	Check the wiring for loose contacts and secure them if found.
			Ensure you are using a correct communication cable.
	No communication with the PC (RS232 Port error)	Wrong/broken cable	Ensure the correct communication cable is being used (PGMCBL).
		Wrong communication port settings	Check and correct the COM port attributes.
		Wrong COM port assignment on the computer	Check if correct Serial Port (COM1) of the computer has been selected.

## **Still Need Help?**

### **Technical Support**

Most of the frequently encountered problems regarding the EZ3 Series unit's operation are answered in the sections above. However, if you still need answers to your questions, please call our technical support at 1-877-774-EASY.

### **Warranty Repairs**

If your EZ3 Series is under warranty, contact us at 1-877-774-EASY.

### **Out of Warranty Services**

If your EZ3 Series is out of warranty, contact EZ Automation at 1-877-774-EASY for an evaluation of repair costs. You can then decide whether it is more economical to proceed with the repairs or to upgrade your system with a new unit.